

Warranty

Universal Host is covered by a 2-year warranty to be free from defective workmanship and materials. In the event that the Universal Host needs repair, you must call us to get an authorization, and then carefully pack and ship it to us. You will pay for shipping to us and we will pay for return back to you, UPS ground. No free repairs will be made if the defect was caused by misuse, weather conditions, or other cause, except for defective workmanship or materials. THERE ARE NO EXPRESSED OR IMPLIED WARRANTIES WHICH EXTEND BEYOND THE WARRANTY HERE MADE.

Universal Host

Desktop Digital Hybrid



User Guide

1010

Introduction

Universal Host will allow you to send and receive audio through your multi-line PBX, ISDN, VoIP or analog telephone. While this may seem like a simple task that any telephone can do, the challenge is getting the best quality audio from such a limited audio path. The USB feature will function as a remote sound card when connected to your computer, eliminating the need for another audio interface with more cables and level adjustments. No additional software drivers are needed for the USB audio interface.

What is a Digital Hybrid?

The Universal Host digital hybrid connects audio signals to and from the handset side of a telephone without the variations in quality found with analog hybrids. The main function of a hybrid is to bring in the caller's voice from the phone line as clear and clean as possible. In the real world, when you send your voice down the telephone line it has a tendency to bleed over into the caller's audio. The hybrid must adapt to the audio signals from the telephone in order to properly separate transmit and receive audio. We use a 16 bit DSP (Digital Signal Processor) to continuously monitor the phone line and local audio signals to deliver excellent trans-hybrid loss, also known as separation. Our dual-convergence algorithm can achieve excellent separation, typically exceeding 50 dB.

Ready to go?

The Universal Host controls and connectors are clearly marked and ready for operation. The Features diagrams and Operation sections on the following pages will help you pinpoint any minor questions that you may have. If this is your first exposure to a hybrid, we suggest that you read the entire manual to allow you to take advantage of all these features.

Any Questions?

Before you pick up the phone... Please thumb through the rest of this manual. You might find those deep technical questions are covered on later pages.

FCC Registration (continued)

- b) The telephone equipment's FCC registration number. This can be found on the bottom of your telephone equipment, and,
- c) The ringer equivalence number (REN) for this equipment.

The REN is used to determine the quantity of devices which will be connected to the telephone line. Excessive RENs on the telephone line may result in the devices not ringing in response to an incoming call. In most, but not all areas, the sum of the RENs should not exceed 5.0. To be certain of the number of devices that may be connected to the line, as determined by the total RENs, contact the local telephone company.

3. Repair Instructions

If it is determined that your telephone equipment is malfunctioning, the FCC requires that it not be used and that it be unplugged from the modular outlet until the problem has been corrected. Repairs to this telephone equipment can only be made by the manufacturer or its authorized agents or by others who may be authorized by the FCC. For repair procedures, follow the instructions outlined under the warranty section of the manual.

4. Rights of the telephone company

If telephone equipment is causing harm to the network, the telephone company may temporarily discontinue your telephone service. If possible, they'll notify you before they interrupt service. If advanced notice isn't practical, you'll be notified as soon as possible. You'll be given the opportunity to correct the problem, and you'll be informed of your right to file a complaint with the FCC.

Your telephone company may make changes in its facilities, equipment, operations or procedures that could affect the proper functioning of your JK Audio product. If such changes are planned, you'll be notified by your telephone company.

FCC Part 15 Compliance

This equipment has been tested and found to comply with the limits for a Class A digital device, pursuant to Part 15 of the FCC Rules. These limits are designed to provide reasonable protection against harmful interference when the equipment is operated in a commercial environment. This equipment generates, uses, and can radiate radio frequency energy and, if not installed and used in accordance with the instruction manual, may cause harmful interference to radio communications. Operation of this equipment in a residential area is likely to cause harmful interference in which case the user will be required to correct the interference at his own expense.

Changes or modifications not expressly approved by JK Audio can void the user's authority to operate the equipment.

FCC Registration

Your new JK Audio product has been registered with the Federal Communications Commission (FCC). This product complies with the standards in Part 68 of the FCC rules.

1. Connection and use with the nationwide telephone network

The FCC requires that you connect this telephone equipment to the national telephone network through a USOC RJ-11C modular telephone jack.

This equipment may not be used with Party Line Service or Coin Telephone Lines.

This equipment is hearing aid compatible.

2. Information for the telephone company

Upon request from your local telephone company, you are required to provide the following information:

- a) The "line" to which you will connect the telephone equipment (that is, your telephone number), and

Features

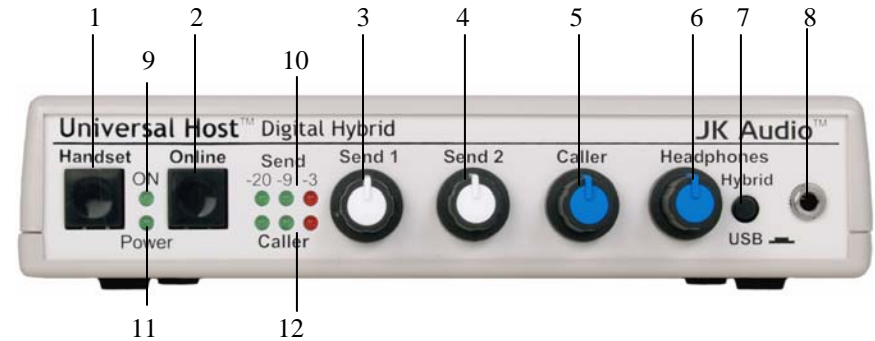

1. Handset Button - Press this button to use the handset as if you were on a normal telephone call.
2. Online Button - Press this button to disable the handset and activate the Universal Host for use as a digital hybrid.
3. Send 1 Level - Adjusts the signal level that you are sending down the telephone line, through the female XLR input.
4. Send 2 Level - Adjusts the signal level that you are sending down the telephone line, through the 3.5mm mini jack input.
5. Caller Level - Adjusts the level of the signal coming in from the telephone line, as it is going out the output jacks.
6. Headphone Level - Adjusts the signal level coming from the 3.5mm front panel headphone jack.
7. Hybrid/USB - Selects audio heard at the headphone output.
8. Headphones - The 3.5mm stereo headphone jack contains either a mix of both the Send input audio and the Caller audio when the button is in the Hybrid position or stereo audio from the USB port with the button in the USB position.
9. ON LED - Lit when you are on line with a call using the hybrid.
10. Send LEDs - Displays the signal level going to the phone line.
11. Power LED - Lit when unit is plugged in and receiving power.
12. Receive LEDs - Displays the signal level coming from the telephone, after the DSP. This signal level will not change when you adjust the Caller knob.

Features (continued)

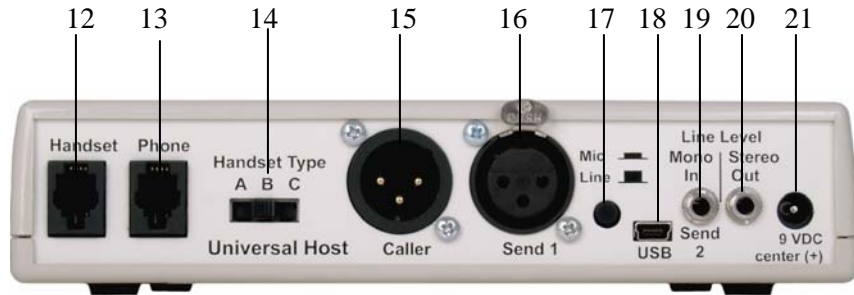

12. Handset Jack - Connect your telephone handset to this jack.
13. Phone Jack - Connect this jack to the handset jack on your telephone using the supplied handset jumper cable.
14. Handset Type Selector Switch - Use this switch to select the correct type of handset microphone that your telephone uses. A=Electret, B=Carbon, C=Dynamic
15. Caller Output - Male balanced XLR output contains only the caller's voice.
16. Send 1 Input - Female balanced XLR input for audio going into the phone line. Mic or line level input.
17. Mic / Line switch - Sets the front end sensitivity of the Send 1 XLR jack. Set to *Mic* if you intend to connect a dynamic microphone directly to the Send 1 jack. Set to *Line* if you are connecting to the output of a mic mixer.
18. USB port - for bi-directional audio connection to your computer or other equipment.
19. Send 2 Mono Input - 3.5mm mono mini jack input for signals going into the phone line. Line level.
20. Stereo Output - 3.5 mm stereo mini jack output contains Send and Caller audio determined by the Send 1 and Send 2 levels and the Caller level controls. Left channel contains your local Send audio mixed with audio from the USB connector and right channel contains the Caller's audio from the phone line.
21. Power Jack - For connection only to the supplied 9 VDC regulated power supply only.

Block Diagram

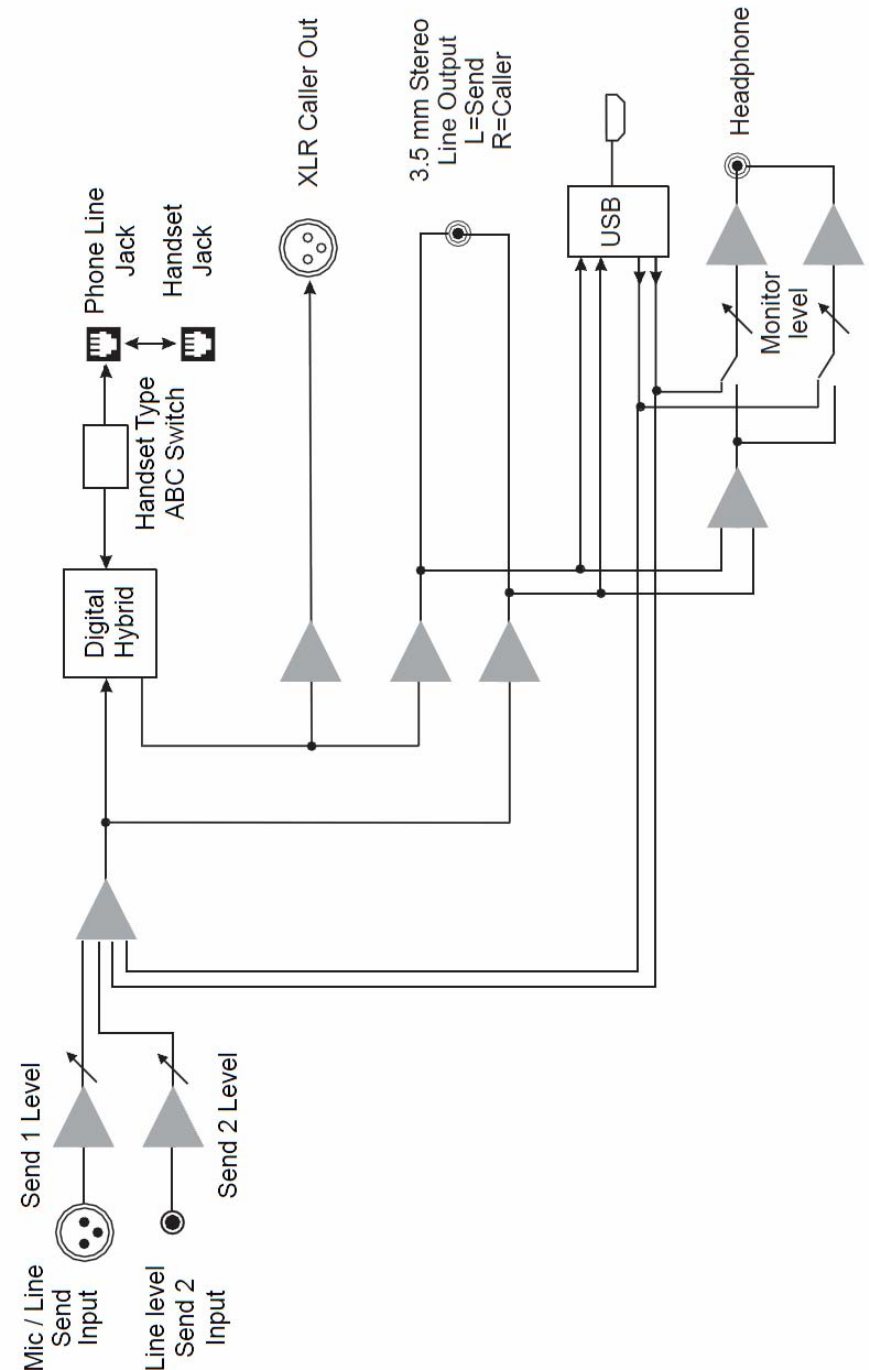

Specifications

Inputs:

Send 1:	Balanced Female XLR, 1k ohms, 15 mV RMS (-34 dBu nom) Mic/Line pad switch = +6 dBu max
Send 2:	3.5mm mono, 20k ohm, 250 mV RMS (-10 dBu nom)

Outputs:

Balanced:	Male XLR, 200 ohms, 500 mV RMS -4 dBu nom, +14 dBu max, Caller only
Unbalanced:	3.5mm stereo, 50 ohm, 250 mV RMS (-10 dBu nom), +6 dBu max Left = Send, Right = Caller
Headphone:	3.5mm stereo, 8 ohms, 1/2 watt per channel, mixed send and receive

USB:

Connector:	Mini Type B female
Standard	v 2.0
Sampling Rates:	32 kHz, 44.1 kHz, 48 kHz
Signal Processing:	16 Bit stereo

Phone Line:

Aux Phone:	RJ22
Phone Line:	RJ22
Isolation:	1500 VAC
Ringer:	0.5B REN
Frequency Response:	Telephone side 200 Hz - 3600 Hz

Power: 120-240 VAC power supply (included)

Size: 7" x 6" x 1.6" (18 x 15 x 4.2 cm)

Weight: 2.2 pounds (1 kg)

Connection

For a direct connection to Universal Host:

- Handset cable - Connect the supplied RJ-22 handset cable between the jack marked "Phone" on the back of Universal Host and to the handset jack on the base of your telephone.
- Handset - Connect your telephone handset to the RJ-22 jack on the back of the Universal Host marked "Handset".
- Send Audio - Connect a dynamic microphone cable to the Send 1 jack on the Universal Host. Be sure to set the Mic/Line switch to the "Mic" position.
- Connect the USB port to your computer or other device to either bring additional local audio into the hybrid or deliver live audio out for recording or streaming.
- Output - Connect a *stereo* cable from the mini jack "Stereo Out" on the Universal Host to the "Line Input" on your desktop PC sound card, mini disk recorder or other equipment.
- Power - Connect the supplied DC power supply to the back of the Universal Host and then to an AC power outlet.
- Place a test call to a quiet location. Set the "A-B-C" switch on Universal Host for best audio. Set the "Send" level control so that while you are speaking into the microphone, the Send LEDs on the hybrid light the -20 dB green LED consistently and flash the -9 dB green LED. If you flash the -3 dB red LED, lower the level. Set the "Caller" control for good recording level of the caller audio at the output jack.

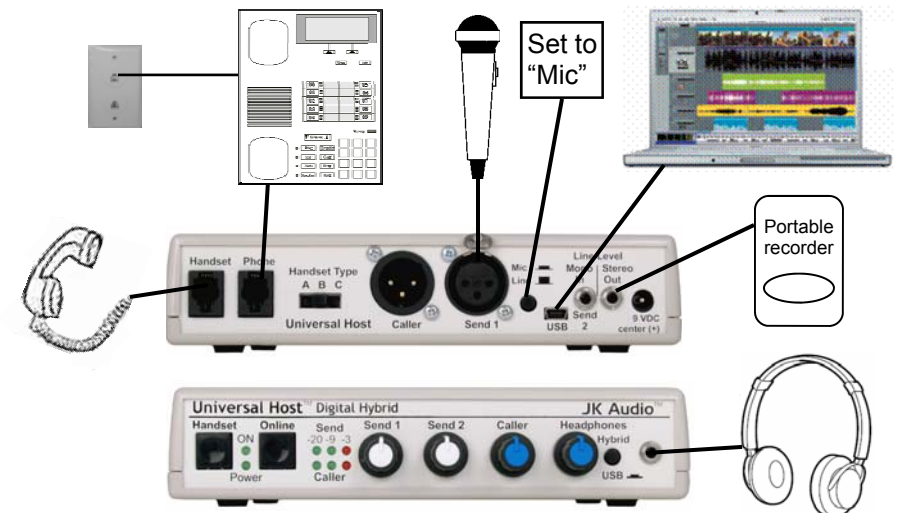

Connection (continued)

To connect Universal Host through a mixer—Mix Minus Setup

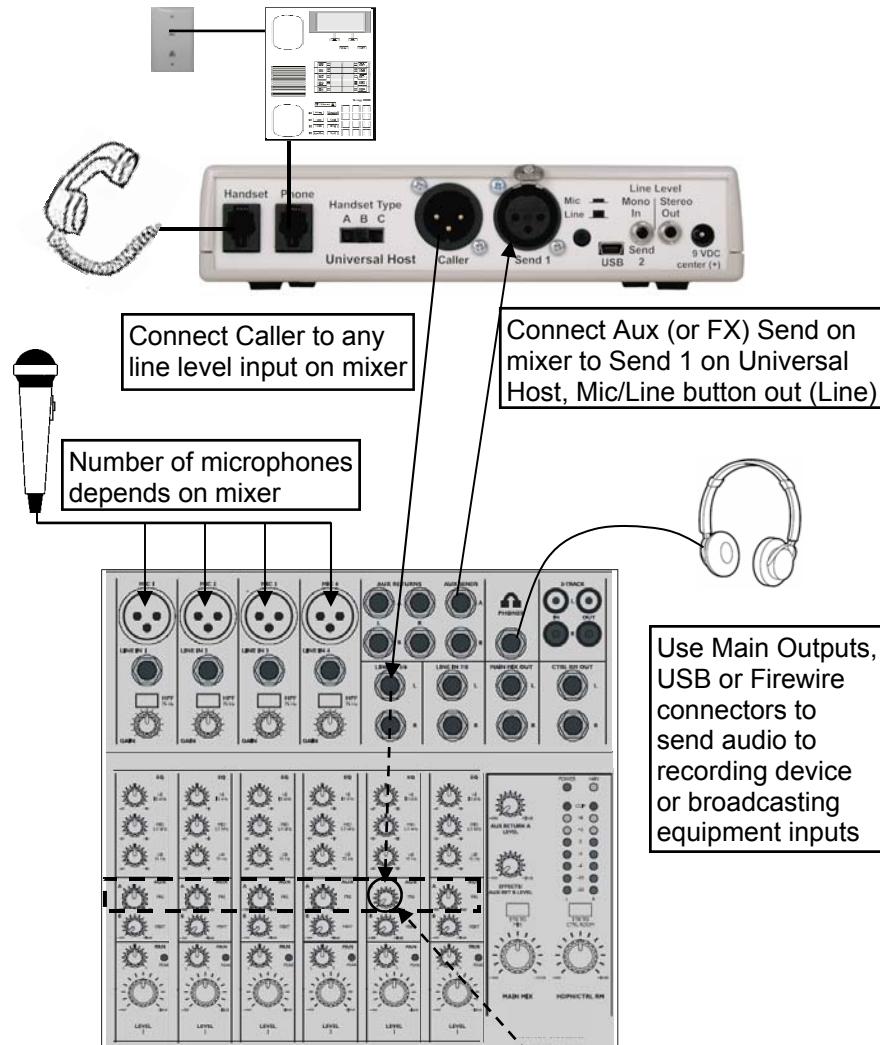

For whichever input channel you have the Caller connected to, turn the corresponding Aux control to minimum (usually hard left). All other Aux controls should be set for what you want to send to the phone line. Each Aux Send bus is completely separate from all other outputs, so these Aux controls will not affect what is heard on the Main outputs or on any other Aux buses. This Aux Send bus should be pre-fader, so you can use the fader controls to set the levels of each channel to the main output.

FAQs

? Why does my laptop only record half of the conversation? I am using the Stereo output on the Universal Host and I have a stereo cable.

! Most laptop computers only have a mic input, which is mono. You should use the USB connector instead for stereo operation.

? How do I record onto my computer and edit the files?

! If your computer does not already have something, you will need to purchase or download any audio editing software of your choice to record and edit audio files. You may also need to adjust some settings in the audio configuration files on your computer or in your software to allow recording in stereo.

? Does Universal Host come with any Talk Show software?

! No, our description "Turn your PBX into a low cost talk show system" pertains to using a multi-line PBX phone system as a line selector switch. When the Universal Host is on line, simply select which phone line you want to talk to, either dropping the last caller, or putting them back on hold.

? Do I need any software drivers for the USB interface?

! No, the USB interface is plug and play compatible.

? Why is there a Send 2 mini-jack on the back of my Universal Host?

! This is a second line level input to Universal Host. Here you can connect another device, such as a CD player or the output of your personal audio player to add audio to the conversation. This enables you to play background music or other sound bites during your discussion. Do not connect a microphone to this jack. This is a mono input. If you connect a stereo output here such as a Line Out from your audio player, you will receive only Left channel audio on this jack.

? Why is there a loud hum on the output of my Universal Host, even when nothing else is connected?

! Make certain you are using the regulated power supply that was shipped with this unit. Power supplies are not all the same.

FAQs

? Will Universal Host work with my phone system?

! Probably yes. The three handset microphone types that we support, electret, dynamic and carbon, cover every handset microphone type that we have seen in use, but the wiring in each phone can change without notice. Universal Host works with virtually any PBX, ISDN, VoIP or even a plain old analog telephone as long as the telephone has a standard handset.

? Will your digital hybrid provide phantom power for a condenser mic?

! No, this device will not provide phantom power. If you connect your mic directly to the Universal Host, use a dynamic mic.

? Why can't I dial out on my phone and I hear a lot of noise on the call?

! The Universal Host will not work with any telephone that has a keypad in the handset. You need to use a telephone with a standard handset.

? Can Universal Host auto-answer or auto-disconnect?

! No, the handset cord on your phone is only active if the handset is off-hook. This must be done manually. So there is no way to auto-disconnect. You must return the handset to the cradle.

? I have everything connected correctly. Why can't the caller hear me?

! There are two things you should check: First, the position of the A-B-C switch which will probably use either setting A or C. Next, you cannot use the speakerphone function on your telephone during your recording. Universal Host accesses audio through the handset cord. With the speakerphone turned on, there is no audio going through the handset. You must use a microphone.

? Can I still use my phone to take regular calls or do I have to disconnect the Universal Host when I am not using it?

! You can leave the Universal Host in place and your telephone will continue to operate normally. Audio will only pass through the hybrid when you press the "Online" button.

Operation

- Using balanced XLR cables (not included) with 1/4" TRS adapters if necessary for your mixer, make all connections as shown.
- On your mixer and on Universal Host, set all controls to nominal levels, usually 12:00.
- On your mixer, set local microphone channel input gain for good microphone level.
- On your mixer, set all output faders and the main mix control for good recording level of the local audio.
- On your mixer, set the headphone level for comfortable listening.
- On your mixer, set the Caller channel input gain to line level, if there is a selector switch. If there is no line level input and you must connect the Caller to a Mic in, turn the input gain way down.
- On your mixer, set the Aux control for Caller channel only to minimum (zero or ∞). Aux controls for all other channels should initially be set at 12:00. Set Aux Send Master for good overall level.
- Place a test call to a quiet location. Set the A-B-C switch on the Universal Host for best audio. If the Receive LEDs on the Universal Host are lighting the red -3 dB, use the controls on the base of your telephone to reduce the incoming Caller volume.
- On your mixer, set the Aux Send control so that while you are speaking into the microphone the Send LEDs on the hybrid light the -20 dB green LED consistently and flash the -9 dB green LED. An occasional flash of the -3 dB red LED is acceptable. If the red LED stays on, lower the level.
- If you need to adjust the Caller level, first set the caller channel input gain on the mixer, then adjust the Caller knob on the hybrid.

Mix-Minus Setup

A mix-minus signal is an audio signal that contains a mix of your local microphones plus any other audio, minus the Caller's own voice. Sending the Caller's own audio back to the Universal Host through Send 1 will cause an echo, or feedback.

If your mixer does not have an Aux Send bus, you can achieve the same results using Pan controls with the Left and Right outputs. Simply pan the Caller to the Right output. Then connect only the Left output to the Universal Host Send 1. Or, you may use an external Mix-Minus box that will create this signal for you.

Operation (continued)

Telephone Handset

Universal Host will disable the microphone in the telephone handset when you press the Broadcast button. Use your telephone to place or screen a call. When you are ready to take the call on Universal Host, simply press the Broadcast button. Universal Host will automatically release the Hold (if Hold is used). **Make sure you do not put the telephone handset back in its cradle while you are on a call.** This will still drop the call. **Do not disconnect or remove the handset during your call** as this will change the input impedance from the phone line and change the audio level.

To take the call back on your telephone, press the Handset button on Universal Host. This will disable the Universal Host and reconnect your handset to the telephone. Your telephone will operate as a normal telephone anytime you are in Handset mode. Leaving the hybrid connected to the handset jack on your telephone will not affect normal use of your telephone. Audio will only pass through the hybrid when you press the Broadcast button.

Optional Jumper Settings

There is a jumper located inside the Universal Host at **J9** that affects handset operation. The factory default closed position (jumper covering both pins) disables only the handset microphone when the Broadcast button is pressed. Changing the jumper to the open position (either remove the jumper or cover just one pin) allows you to completely disable both the handset microphone and the speaker when the Broadcast button is pressed.

If the incoming audio level from your telephone is too high and you are consistently lighting the red -3dB Receive LED, first try decreasing the volume using the controls on the base of your telephone. If you still cannot drop the incoming audio level enough, you may need to change jumper **J10** inside Universal Host. There are three possible settings to adjust Caller receive level:

- Pins 1 & 2 closed = 0 dB (factory default)
- Pins 2 & 3 closed = -10 dB
- Pins 1-3 left open = -20 dB

To change the jumper settings, first disconnect power from the Universal Host, then remove the four screws on the bottom that hold the cover on. Slide the top cover up to remove it and locate the appropriate jumpers on the printed circuit board.

Operation (continued)

Send Signal Level

The Send LEDs display the signal level as it goes out to the phone line. The goal is to drive the phone line at high enough levels to be heard well at the other end, but not so loud as to cause excessive clipping. Adjust the Send level control so that you occasionally see flashes of the red -3dB peak Send LED. If the red LED stays lit for extended periods you should decrease the Send volume control for the input that is causing the clipping.

Caller Signal Level

The Receive LEDs only display the strength of the signal coming in from the phone line. The Caller level control does not change what you see on these LEDs. Adjust the Caller level for the best signal at the output jacks of Universal Host.

A-B-C Selector Switch

Use this switch to select the correct type of handset microphone your telephone uses. A=Electret, B=Carbon, C=Dynamic. Trial and error seems to work best in determining which handset type to use. Your Universal Host will only function correctly if the handset type selector switch is in the correct position. This switch changes signal level, impedance, and wiring to accommodate the differences in handset microphone types.

Although not conclusive, the following guidelines may help:

Many AT&T[®], SW Bell[®] and Sony[®] telephones have electret type microphones and will use the "A" position.

Only older telephones that have the round "screw on" type handsets contain carbon microphones and use the "B" position.

Many Radio Shack[®], Panasonic[®], Nortel[®] and some newer AT&T[®] phones have dynamic microphone types and use the "C" position.

USB Connector

Using the cable provided, you can connect this USB port to your computer or other audio device. This will enable you to send stereo audio to your computer or other recording device with your local audio on the left channel and the caller on the right. You can also use the USB port to play audio from your computer to the phone caller, but it will not be sent to the Caller XLR output jack. It will be mixed with your Send audio on the stereo mini output. You can send and receive audio at the same time through the USB port.