

Vision+ 4KZ

User Manual



User Manual



TABLE OF CONTENTS

TABLE OF CONTENTS.....	2
SAFETY INSTRUCTIONS.....	3
PACKING LIST.....	4
QUICK START.....	5
PRODUCT HIGHLIGHTS.....	6
CAMERA SPECIFICATION.....	8
INTERFACES.....	10
DIMENSIONS (MILLIMETERS).....	11
VISCA PROTOCOL.....	14
OSD MENU.....	24
IP ADDRESS SETTINGS IN THE MENU.....	28
CAMERA BUTTON FUNCTIONS.....	28
WEB INTERFACE.....	29
VIEW RTSP VIDEO USING VLC PLAYER.....	33
USING NDI TOOLS.....	34
VISCA OVER IP.....	36



SAFETY INSTRUCTIONS

1. Before operation, please fully read and follow all instructions in the manual. For your safety, always keep this manual with the camera.
2. The camera power voltage is 12V DC, rated current is 5A. We suggest you use it with the original power supply adapter supplied by the factory.
3. Please keep the power cable, video cable and control cable in a safe place. Protect all cables especially the connectors.
4. Operational environment: 0°C~50°C, humidity less than 90%.
5. To avoid any danger, please keep the camera away from the corrosive liquid.
6. Avoid stress, vibration and damp during transportation, storage and installation.
7. Do not remove the camera housing and cover. For any service, please contact authorized technicians.
8. Video cable and control cable should be individually shielded, and cannot be substituted with other cables. Do not direct the camera lens towards strong light, such as the sun or the intensive light.
9. Use a dry and soft cloth to clean the camera housing. Applied with neutral cleaning agent when there is need to clean. To avoid damage on the camera lens, never use strong or abrasive cleaning agents on the camera housing.
10. Do not move the camera by holding the camera head. To avoid mechanical trouble, do not rotate the camera head by hand.
11. Put the camera on fixed and smooth desk or platform, avoid leaned installation.
12. Power Supply Polarity:

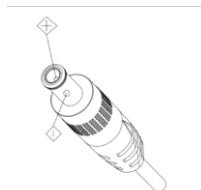



PACKING LIST

Check all below items when open the package

Camera	1PCS
Power Adapter.....	1PCS
Power Cable	1PCS
Remote Controller.....	1PCS
USB Type-A Cable.....	1PCS
RS232 Cable	1PCS



QUICK START

1. Please check if the wiring is correct before turning on the device.

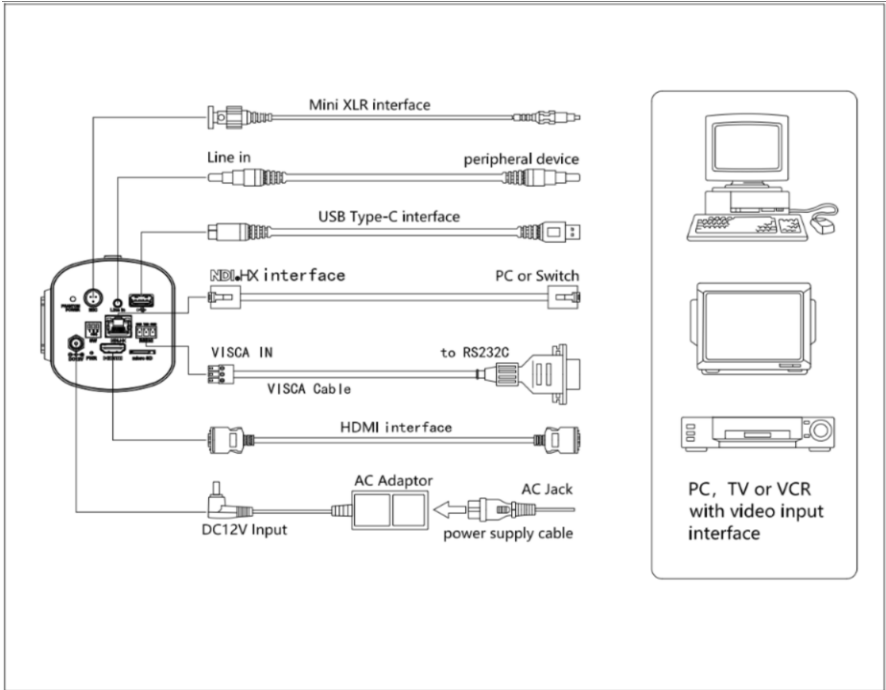

2. Bottom DIP Switch

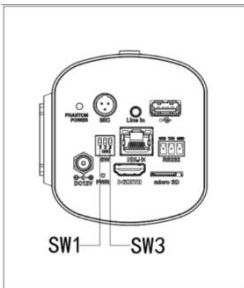

DIP Switch Definition				
	SW-1	SW-2	SW-3	说明
1	OFF	ON	OFF	Operation Mode
2	ON	ON	OFF	ARM Upgrade Mode
3	OFF	ON	ON	ISP Upgrade Mode
4	Other			Reserved



PRODUCT HIGHLIGHTS

- **4K UHD Resolution:**

Experience breathtaking detail and clarity with ultra-high-definition 4K (3840 x 2160) video at 60fps via HDMI. Our advanced image processing ensures lifelike images, even in low-light conditions.

- **20x Optical Zoom:**

Capture every detail with the 20x optical zoom lens. The 60-degree FOV and proprietary focusing algorithm deliver fast and precise focus performance, even during zoom and movement.

- **Perfect Color Match for Multi-Camera Productions**

The Vision+ 4KZ box camera solves color and visual inconsistency in multi-camera productions by using the same high-quality lens, sensor, and processor as the Vision+ 4KN 20x PTZ, ensuring a consistent look across fixed and PTZ setups.

- **One Camera Two Shot:**

When outputting at 1080P or lower resolutions, the IP sub-stream (supporting RTSP/RTMP/SRT/NDI protocols) enables CROP output, allowing seamless switching between panoramic and CROP views via HDMI/USB interfaces.

- **Dual Smart Tracking Modes (Auto Framing & Auto Tracking):**

In CROP mode, two intelligent tracking options are available: Auto Framing & Auto Tracking. Auto Framing dynamically adjusts the frame to keep the subject perfectly centered. Auto Tracking uses advanced AI algorithms to identify and follow the subject even in complex environments.

- **Side Control Panel for Key Image Parameters & IP Address:**

Quickly access and adjust essential image parameters and view the IP address directly on the camera's side panel, streamlining your workflow.

- **Free D Technology Integration:**

The Explore seamlessly integrates FreeD technology, empowering users to explore dynamic shooting angles and perspectives, making it ideal for versatile real-world and virtual-world applications.

- **Versatile Output Options:**
Select the ideal 4K output—NDI|HX3 (4K30) or HDMI (4K60)—to match your production requirements. Engineered for seamless integration, it effortlessly adapts to professional workflows.
- **Robust Audio Capabilities:**
Professional-grade audio inputs include a 3.5mm line-in and a Mini XLR input with phantom power support, ensuring compatibility with various microphones and audio equipment.
- **Local Recording for Backup and Cloud Production:**
Record directly to a MicroSD card (up to 512GB) for instant backup, easy event review, and seamless file upload to your preferred cloud platform.
- **Seamless Camera Setup with SSDP:**
Simplify camera setup with SSDP integration. Easily find your camera's IP address on the local network, especially in multi-camera setups.
- **Embed the Latest NDI®HX3 SDK:**
Leverage the power of Newtek's NDI®HX3 for plug-and-play compatibility with various live streaming products and platforms, creating diverse and engaging content.
- **Program and Preview Tally:**
The built-in indicator light functions as a tally light, providing clear visual feedback on live status when receiving tally notifications from NDI® devices.



CAMERA SPECIFICATION

Camera	Vision+ 4KZ 20X
Part Number	TLC-600-IP-20-4K(NDI)-AB
Sensor	1/1.8-inch, 9MP UHD CMOS sensor
Zoom	20x optical zoom
Lens	f = 6.25mm ~ 112.5mm, F1.58 ~ F3.96
Horizontal View Angle	61° (Wide) ~ 3.5° (Tele)
Vertical viewing angle	34.1° ~ 1.9°
Diagonal viewing angle	60.7° ~ 3.5°
Minimum Working Distance	1.0m
S/N Ratio	≥50dB
Video Format	HDMI2.0: 3840*2160P60/59.94/50/30/29.97/25 1920*1080P60/59.94/50/30/29.97/25/24/23.98 ; 1920*1080I60/59.94/50 ; 1280*720P60/59.94/50/30/29.97/25 NDI@JHX3: Main Stream: 3840*2160P15~30; 1920*1080P15~60; 1280*720P15~60; 1024*576P15~60 Sub Stream (CROP): 1920*1080P15~60; 1280*720P15~60; 1024*576P15~60;640*360P15~60; USB 2.0: NV12: 1920*1080P5; 1280*720P10; 1024*576P15; 800*448P30/25 YUYV: 1920*1080P5; 1280*720P10; 1024*576P15; 800*448P20/15 MJPG: 1080P60/50/30/25; 1280*720P60/50/30/25; 1024*576P60/50/30/25; 800*448P60/50/30/25



Image Parameters

Noise Reduction	2D&3D
Minimum lux	0.5Lux (50 IRE Max AGC,1/30, F1.8)
White Balance	Auto/Manual/Auto tracking/Push/Indoor/Outdoor/Color Temperature
Exposure	Auto/Manual/Shutter Priority/Iris Priority/Brightness Priority
Anti-Flicker	OFF,50Hz,60Hz
Image Flip	Support
Mirroring	Support
Focus	Auto/Manual
Iris	Auto/Manual
Electronic-shutter	Auto/Manual
Gamma	Support
Backlight Compensation	Support

IP Streaming

Video Encoding	H.264/H.265
Bitrate Control	Variable bitrate(VBR), Constant bitrate(CBR)
Bitrate Range	1024Kbps~61440Kbps
Network Port Speed	1000M
Protocol	NDI@HX3, FreeD, SRT, HTTP, RTSP, RTMP, ONVIF, VISCA over IP(TCP&UDP), VISCA, PELCO P/D, SSDP, NTP, RTP Multicast, WebRTC

I/O Interface

Control Port	RS232, RJ45
Video Port	NDI@HX3, HDMI2.0, USB Type-A
Audio Port	Stereo 3.5mm linear inputs, mini XLR
Tally	Support
POE	Support

General

Input Voltage	DC12V, POE+(IEEE802.3at)
----------------------	--------------------------



Operating Temperature	-10°C ~ 50°C
Operating Humidity	≤80%
Color	Black
Dimension (L×W×H)	82mm×85.3mm×186.5mm
Net Weight	0.95kg(2.09LBS)

INTERFACES

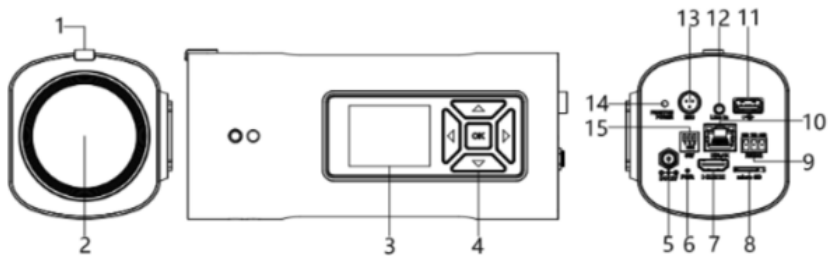

- | | | | |
|--------------------|------------------------|-------------------|-----------------------------|
| 1. Tally Indicator | 5. 12V Power Interface | 9. RS232 | 13. XLR |
| 2. Lens | 6. Power Indicator | 10. RJ45(NDI® HX) | 14. Phantom Power Indicator |
| 3. LCD Screen | 7. HDMI | 11. USB-A | 15. DIP Switch |
| 4. Button | 8. MicroSD slot | 12. Line-in | |



DIMENSIONS (MILLIMETERS)

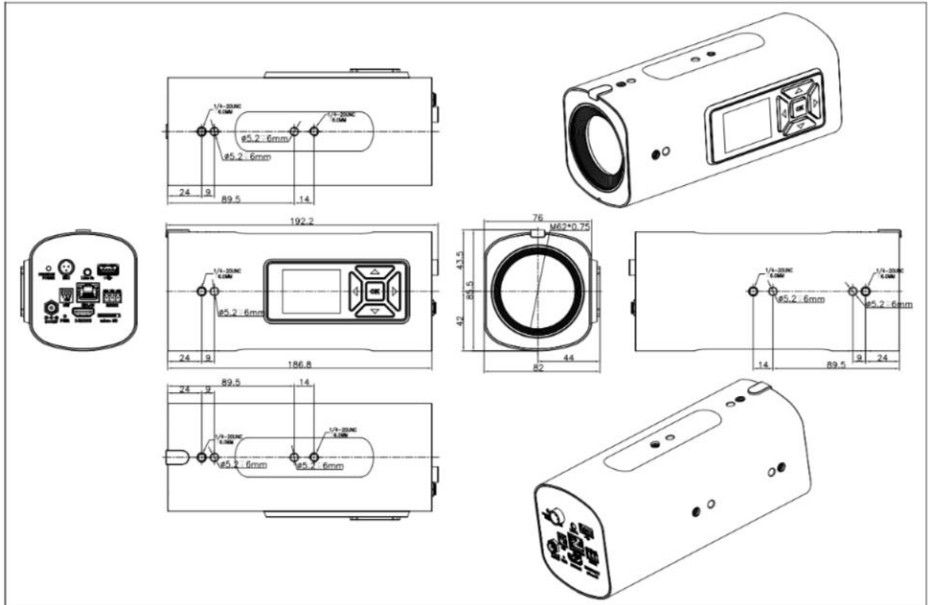

INFRARED REMOTE CONTROL



LED Function Indicators

Red light on key press: Indicates the camera is currently selected for control.

Green light on key press: Indicates the conference terminal is selected (learning required).

Blue light on key press: Indicates the TV is selected (learning required).

Power Keys

- **Red key:** In normal mode, short press puts the camera into standby. Press again to reboot the camera, returning it to the HOME position or Preset 1 if saved.
- **Green key:** Power key for conference terminal (learning required).
- **Blue key:** Power key for TV (learning required).



Focus Adjustment (+/-)

Manually adjusts focus; effective only in manual focus mode.

Zoom Adjustment (+/-)

Adjusts the zoom level of the lens.

Navigation Keys (Up/Down/Left/Right)

- ◇ In normal mode: Adjust the position of the electronic PTZ.
- ◇ In menu mode: Navigate and adjust menu parameters.



Confirm/Home Key:



- In normal mode: Short press returns the electronic PTZ to the HOME position.
- In menu mode: Confirms the selected menu item.



Menu Key

- In normal mode: Opens the settings menu.
- In menu mode: Returns to the previous menu level.



Numeric Keys

- **Save preset:** Long press (3 seconds) to save the current PTZ position to the corresponding preset.
- **Delete preset:** Press "Delete" + number key to remove the corresponding preset. Long press "Delete" for 3 seconds to clear all presets.
- **Recall preset:** Short press the number key to recall the corresponding preset.



VISCA Protocol

PART 1: CAMERA RETURN COMMANDS

Ack/Completion Message		
	Command	Note
ACK	z0 41 FF	Command successfully accepted
Completion	z0 51 FF	Command successfully executed

z = Camera Address + 8

Error Messages		
	Command	Note
Syntax Error	z0 60 02 FF	Command does not exist or is incorrect
Command Not Executable	z0 61 41 FF	Command cannot be executed, such as attempting manual focus in autofocus mode.

PART 2: CAMERA CONTROL COMMANDS

Command type	function	command		
Address Set	Broadcast	88 30 01 FF	Address setting	
IF_Clear	Broadcast	88 01 00 01 FF	I/F Clear	
Command Cancel		8x 21 FF		
CAM_Power	On	8x 01 04 00 02 FF	Power ON/OFF	
	Off	8x 01 04 00 03 FF		
CAM_Zoom	Stop	8x 01 04 07 00 FF	p = 0(low)~7(high)	
	Tele(Standard)	8x 01 04 07 02 FF		
	Wide(Standard)	8x 01 04 07 03 FF		
	Tele(Variable)	8x 01 04 07 2p FF		
	Wide(Variable)	8x 01 04 07 3p FF		
	Direct	8x 01 04 47 0p 0q 0r 0s FF		pqrs: Zoom Position (0(wide)~0x4000(tele))
	Direct with speed	8x 0A 04 47 0t 0p 0q 0r 0s FF		t: spd 0~7
CAM_DZoom	ON	8x 01 04 06 02 FF	Combine with optical zoom control	
	OFF	8x 01 04 06 03 FF		
	Combine Mode	8x 01 04 36 00 FF		
	Separate Mode	8x 01 04 36 01 FF		
	Stop	8x 01 04 06 00 FF		
	Tele (Variable)	8x 01 04 06 2p FF		Enable In separate mode

Command type	function	command	
	Wide (Variable)	8x 01 04 06 3p FF	Enable In separate mode
	Direct	8x 01 04 46 0p 0q 0r 0s	Enable In separate mode
CAM_Focus	Stop	8x 01 04 08 00 FF	
	Far(Standard)	8x 01 04 08 02 FF	
	Near(Standard)	8x 01 04 08 03 FF	
	Far (Variable)	8x 01 04 08 2p FF	p=0 (Low) to 7 (High)
	Near (Variable)	8x 01 04 08 3p FF	p=0 (Low) to 7 (High)
	Direct	8x 01 04 48 0p 0q 0r 0s FF	pqrs: Focus Position
	Auto Focus	8x 01 04 38 02 FF	
	Manual Focus	8x 01 04 38 03 FF	
	One Push AF	8x 01 04 18 01 FF	
CAM_Zoom Focus	Direct	8x 01 04 47 0p 0q 0r 0s 0t 0u 0v 0w FF	pqrs: Zoom Position (0(wide)~ 0x4000(tele))
CAM_WB	Auto	8x 01 04 35 00 FF	
	Indoor	8x 01 04 35 01 FF	
	Outdoor	8x 01 04 35 02 FF	
	One Push	8x 01 04 35 03 FF	
	ATW	8x 01 04 35 04 FF	
	Manual	8x 01 04 35 05 FF	
	One Push	8x 01 04 10 05 FF	
CAM_R Gain	Reset	8x 01 04 03 00 FF	Manual Control of R Gain
	Up	8x 01 04 03 02 FF	
	Down	8x 01 04 03 03 FF	
	Direct	8x 01 04 43 00 00 0p 0q FF	pq: R Gain (0~0xFF)
CAM_B Gain	Reset	8x 01 04 04 00 FF	Manual Control of B Gain
	Up	8x 01 04 04 02 FF	
	Down	8x 01 04 04 03 FF	
	Direct	8x 01 04 44 00 00 0p 0q FF	pq: B Gain (0~0xFF)
CAM_AE	Full Auto	8x01 04 39 00 FF	Automatic Exposure mode
	Manual	8x 01 04 39 03 FF	Manual Control mode
	Shutter Priority	8x 01 04 39 0A FF	Shutter Priority
	Iris Priority	8x 01 04 39 0B FF	Iris Priority Automatic
	Bright	8x 01 04 39 0D FF	Bright Mode (Manual control)
CAM_Shutter	Reset	8x 01 04 0A 00 FF	Shutter Setting
	Up	8x 01 04 0A 02 FF	
	Down	8x 01 04 0A 03 FF	
	Direct	8x 01 04 4A 00 00 0p 0q FF	pq: Shutter Position (0~0x15)
CAM_Iris	Reset	8x 01 04 0B 00 FF	Iris Setting(0~0xD)
	Up	8x 01 04 0B 02 FF	
	Down	8x 01 04 0B 03 FF	
	Direct	8x 01 04 4B 00 00 0p 0q FF	pq: Iris Position (0~ 0x11)
CAM_Gain	Reset	8x 01 04 0C 00 FF	Gain Setting (0~0x0F)
	Up	8x 01 04 0C 02 FF	
	Down	8x 01 04 0C 03 FF	
	Direct	8x 01 04 0C 00 00 0p 0q FF	pq: Gain Positon (0~0x0E)

Command type	function	command	
	GainLimit	8x 01 04 2C 0p FF	p:GainLimt 0x04~0x0F
CAM_AEBright	Reset	8x 01 04 0D 00 FF	Bright Setting
	Up	8x 01 04 0D 02 FF	
	Down	8x 01 04 0D 03 FF	
	Direct	8x 01 04 4D 00 00 0p 0q FF	
CAM_ImageBright	Direct	8x 01 04 A4 00 00 0p 0q FF	pq: Image Bright Positon (0~0x1B) AE_BRIGHT pq: Image Bright Positon (0~0x0F) AE_AUTO/AE_SHUTTER/AE_IRIS
CAM_WDR	On	8x 01 04 3D 02 FF	Exposure Compensation ON/OFF
	Off	8x 01 04 3D 03 FF	
	Direct	8x 01 04 D3 pq FF	
CAM_Back Light(BLC)	On	8x 01 04 33 02 FF	BackLight On
	Off	8x 01 04 33 03 FF	BackLight Off
CAM_Sharpness	Reset	8x 01 04 02 00 FF	Aperture Control
	Up	8x 01 04 02 02 FF	
	Down	8x 01 04 02 03 FF	
	Direct	8x 01 04 42 00 00 0p 0q	
CAM_Memory(pre set)	Reset	8x 01 04 3F 00 pp FF	pp: Preset Number(=0 to 127) Corresponds to 0 to 9 on the Remote Commander
	Set	8x 01 04 3F 01 pp FF	
	Recall	8x 01 04 3F 02 pp FF	
CAM_MemoryH (preset)	Reset	8x 01 04 3F 00 0p 0p FF	pp: Preset Number(=0 to 255) Corresponds to 0 to 9 on the Remote Commander
	Set	8x 01 04 3F 01 0p 0p FF	
	Recall	8x 01 04 3F 02 0p 0p FF	
Freeze	Set	8x 01 04 75 0p FF	p: Freeze switch 3=OFF 2=ON
PresetFreezeSet	Set	8x 01 04 76 0p FF	p: Preset Freeze switch 3= OFF 2=ON
PresetSpeedSet	Set	8x 01 7E 01 0B 00 qq FF	qq:Preset speed 2~24 1=0x15
PresetSpeedAdj	adj	8x 01 7E 01 1B 0p FF	p: direction adjustment
CAM_LR_Reverse	On	8x 01 04 61 02 FF	Image Flip Horizontal ON/OFF
	Off	8x 01 04 61 03 FF	
CAM_Picture Flip	On	8x 01 04 66 02 FF	Image Flip Vertical ON/OFF
	Off	8x 01 04 66 03 FF	
CAM_RS485Ctl	On	8x 01 06 A5 02 FF	
	Off	8x 01 06 A5 03 FF	
CAM_Saturation	Saturation	8x 01 04 A1 00 00 0p 0q FF	pq:saturation level 0x00~0x0f
CAM_Contrast	Contrast	8x 01 04 A2 00 00 0p 0q FF	pq:Contrast level 0x00~0x0f
CAM_Speed By Zoom	On	8x 01 06 A0 02 FF	
	Off	8x 01 06 A0 03 FF	
CAM_PT Speed	PT Speed	8x 01 04 C1 00 00 0p 0q FF	pq:PT speed 0x05~0x18
CAM_Zoom	Zoom Speed	8x 01 04 D1 00 00 0p 0q FF	pq:Zoom speed 0x01~0x07
CAM_Zoom Display	On	8x 01 06 C2 02 FF	
	Off	8x 01 06 C2 03 FF	
CAM_Freeze	Freeze	8x 01 04 75 0p FF	p: Freeze switch 3=OFF, 2=ON
CAM_Preset	Preset Freeze	8x 01 04 76 0p FF	p: Preset Freeze switch 3=OFF, 2=ON



Command type	function	command	
CAM_Preset PT Speed Set	Preset PT Speed Set	8x 01 7E 01 0B 00 qq FF	qq:Preset PT Speed 02~24 default:15
CAM_Preset Zoom Speed Set	Preset Zoom Speed Set	81 01 7E 01 2B 00 qq FF	qq:Preset Zoom Speed 01~07 default:5
CAM_Preset	Preset Speed	8x 01 7E 01 1B 0p FF	p: Adjustment of direction 0=left 2=right
CAM_IR address	IR address	8x 01 06 D8 0p FF	p:IR address 1~4
CAM_Gamma	Gamma set	8x 01 04 5B 0p FF	P:Gamma NO. (0~4)
CAM_2D	Direct	8x 01 04 A5 0p FF	p: 2D noise reduction switch 0 = OFF 1 = ON
CAM_3D Noise Reduction	Direct	8x 01 04 53 0p FF	p: 3D noise reduction switch 0 = OFF 1 = AUTO 2~5 = MANUAL LEVEL
CAM_AT_OnOff	Direct	8x 01 04 C8 0p FF	P: 0 = off
CAM_AT_TargetChange	Target change	8x 01 04 CA 0p FF	P:0x02 right move
CAM_TargetLocation	Target location	8x 01 04 CB 0p FF	P: 0:mid 1:left
CAM_TargetRatio	Target ratio	8x 01 04 CC 0p 0q FF	Pq:(6~20)Human is 1/pq in the pi
CAM_AT_ChangeT	Direct	8x 01 04 CD 0p 0q FF	pq: t*10
CAM_AT_BlackBalance	Direct	8x 01 04 CE 0p FF	p: 1=Enable 0=Disable
CAM_AT_HiLightT	Direct	8x 01 04 CF 0p FF	p: 1=Enable 0=Disable
CAM_AT_LeftUp_Limit	Direct	8x 01 04 3F 0p 0F 0B FF	p: 1=Set 2=Call 3=Clear
CAM_AT_RightDown	Direct	8x 01 04 3F 0p 0F 0D FF	p: 1=Set 2=Call 3=Clear
CAM_AT_InitialPosition	Direct	8x 01 04 3F 0p 0F 0F FF	p: 1=Set 2=Call 3=Clear
CAM_AT_BlackBalance	Direct	8x 01 04 3F 0p 0F 0C FF	p: 1=Set 2=Call 3=Clear
CAM_AT_ZoomLock	Direct	8x 01 04 D6 0p FF	p: 1=Enable 0=Disable
CAM_AT_LimitEnable	Direct	8x 01 04 D7 0p FF	p: 1=Enable 0=Disable
CAM_AudioSet	Direct	8x 01 04 D8 0p 0q 0r 0s 0t 0u 0m 0n 0h 0i 0j FF	0p: 0x01-ON 0x00-OFF 0q: 0x01-line in rstu: samplerate
FLICK	50HZ	8x 01 04 23 01 FF	
	60HZ	8x 01 04 23 02 FF	
	OFF	8x 01 04 23 00 FF	



Command type	function	command	
Video System Set(Factory)		8x 01 06 35 00 pp FF	pp: Video format
			1080P60 0x00
			1080P50 0x01
			1080I60 0x02
			1080I50 0x03
			1080P30 0x04
			1080P25 0x05
			720P60 0x06
720P50 0x07			
Video System Set(Sony)	Direct	81 01 04 24 72 0p 0q FF (HDMI) 81 01 04 24 73 0p 0q FF (SDI1/SFP+) 81 01 04 24 74 00 0m FF (Feature Size)	pq: Video format
			1080P60 0x2e
			1080P50 0x2f
			1080I60 0x01
			1080I50 0x04
			1080P30 0x06
			1080P25 0x08
			720P60 0x09
720P50 0x0c			
CAM_ID Write		8x 01 04 22 0p 0q 0r 0s FF	pqrs: Camera ID (=0000 to FFFF)
DHCP control	DHCP off	8x 01 04 AE 00 FF	DHCP off
	DHCP on	8x 01 04 AE 01 FF	DHCP on
IP address control	IP set	8x 01 04 AB 0p 0q 0r 0s 0m 0n 0x 0y FF	Set ip to: pq.rs.mn.xy
	Mask set	8x 01 04 AC 0p 0q 0r 0s 0m 0n 0x 0y FF	Set mask to: pq.rs.mn.xy
	Gateway set	8x 01 04 AD 0p 0q 0r 0s 0m 0n 0x 0y FF	Set gateway to : pq.rs.mn.xy
Mainstream	resolution	8x 01 04 C2 00 0p 0q 0r 0s 0m 0n 0x 0y FF	pqrs : Column(x size) mnxy: Line (y size) only support:
	rate	8x 01 04 C2 01 0p 0q 0r 0s 0m 0n 0x 0y FF	pqrsmnxy: bitrate



Command type	function	command	
	Encode Mode	8x 01 04 C2 02 0p 0q FF	Mode sel: 0xpq
	Frame Rate	8x 01 04 C2 03 0p 0q FF	Frame rate: 0xpq
	IDR	8x 01 04 C2 04 0p 0q FF	IDR Setting: 0xpq
	Stream Rate Mode	8x 01 04 C2 05 0p 0q FF	Contor mode: 0xpq
Sub stream	resolution	8x 01 04 C3 00 0p 0q 0r 0s 0m 0n 0x 0y FF	pqrs : Column(x size) mnxy: Line (y size)
	rate	8x 01 04 C3 01 0p 0q 0r 0s 0m 0n 0x 0y FF	pqrsmnxy: bitrate
	Encode Mode	8x 01 04 C3 02 0p 0q FF	Mode sel: 0xpq 0x00: h264
	Frame Rate	8x 01 04 C3 03 0p 0q FF	Frame rate: 0xpq
	IDR	8x 01 04 C3 04 0p 0q FF	IDR Setting: 0xpq
	Stream Rate Mode	8x 01 04 C3 05 0p 0q FF	Contor mode: 0xpq
SYS_Menu	Menu On	8x 01 06 06 02 FF	Turn on the menu
	Menu Off	8x 01 06 06 03 FF	Turn off the menu
	Menu Back	8x 01 06 06 10 FF	Menu step back
	Menu OK	8x 01 7E 01 02 00 01 FF	Menu ok
IR_Receive	On	8x 01 06 08 02 FF	IR(remote commander)receive ON/OFF
	Off	8x 01 06 08 03 FF	
	On/Off	8x 01 06 08 10 FF	
Tally Brightness	Direct	8x 01 7E 01 0A 01 0p FF	p: 0: OFF 1: low 2: mddle
Tally control	Tally on/off	8x 01 7E 01 0A 00 0p FF	P: 1: (LED red on)
Pan_tilt Drive	Up	8x 01 06 01 VV WW 03 01 FF	VV: Pan speed 0x01 (low speed) to 0x18 (high speed)
	Down	8x 01 06 01 VV WW 03 02 FF	
	Left	8x 01 06 01 VV WW 01 02 FF	
	Right	8x 01 06 01 VV WW 02 02 FF	WW: Tilt speed 0x01 (low speed) to 0x14 (high speed)
	Up left	8x 01 06 01 VV WW 01 01 FF	
	Up right	8x 01 06 01 VV WW 02 01 FF	YYYY: Pan Position(TBD)
	Down Left	8x 01 06 01 VV WW 01 02 FF	ZZZZ: Tilt Position(TBD)
	Down Right	8x 01 06 01 VV WW 02 02 FF	
	Stop	8x 01 06 01 VV WW 03 02 FF	



Command type	function	command	
	Absolute Position	8x 01 06 02 VV WW 0Y 0Y 0Y 0Y 0Z 0Z 0Z 0Z FF	
	Relative Position	8x 01 06 03 VV WW 0Y 0Y 0Y 0Y 0Z 0Z 0Z 0Z FF	
	Home	8x 01 06 04 FF	
	Reset	8x 01 06 05 FF	
Pan-tilt Limit Set	Set	8x 01 06 07 00 0W 0Y 0Y 0Y 0Y 0Z 0Z 0Z 0Z	W: 1: Up Right 0: Down Left
	Clear	8x 01 06 07 01 0W 07 0F 0F 0F 07 0F 0F 0F	YYYY: Pan Limit Position(TBD)
CAM_Phantompo wer_Set	Direct	8x 01 04 D9 0p FF	p: 2=Enable 3=Disable

PART 3: INQUIRY COMMANDS

Command type	command	return	note
CAM_Power Inq	8x 09 04 00 FF	y0 50 02 FF v0 50 03 FF	On Off(Standby)
CAM_Zoom Pos Inq	8x 09 04 47 FF	y0 50 0p 0q 0r 0s FF	pqrs: Zoom Position
CAM_DZoom On Off Inq	8x 09 04 06 FF	y0 50 0p FF	p: 2: ON 3: OFF
CAM_PT Speed Inq(IR)	8x 09 04 C1 FF	y0 50 pp FF	pp: 0x05~0x18
CAM_Zoom Speed	8x 09 04 D1 FF	y0 50 0p FF	p:0x00~0x07
CAM_Focus Mode Inq	8x 09 04 38 FF	v0 50 02 FF	Auto Focus
		v0 50 03 FF	Manual Focus
CAM_Focus Pos Inq	8x 09 04 48 FF	y0 50 0p 0q 0r 0s FF	pqrs: Focus Position
CAM_2D_Inq	8x 09 04 A5 FF	y0 50 03 FF	(0~0x01)
CAM_3D_Inq	8x 09 04 53 FF	y0 50 03 FF	(0~0x05)
CAM_WB Mode Inq	8x 09 04 35 FF	v0 50 00 FF	Auto
		y0 50 01 FF	Indoor mode
		v0 50 02 FF	Outdoor mode
		v0 50 03 FF	OnePush mode
		v0 50 04 FF	ATW
		v0 50 05 FF	Manual
CAM_RGain Inq	8x 09 04 43 FF	y0 50 00 00 0p 0q	pq: R Gain
CAM_BGain Inq	8x 09 04 44 FF	y0 50 00 00 0p 0q	pq: B Gain
CAM_Saturation Inq	8x 09 04 A1 FF	y0 50 00 00 0p 0q	pq: saturation
CAM_Contrast Inq	8x 09 04 A2 FF	y0 50 00 00 0p 0q	pq: contrast
CAM_AE Mode Inq	8x 09 04 39 FF	y0 50 00 FF	Full Auto
		v0 50 03 FF	Manual
		y0 50 0A FF	Shutter priority
		y0 50 0B FF	Iris priority
		y0 50 0D FF	Bright
CAM_Flicker Mode Inq	8x 09 04 AA FF	y0 50 0p FF	p: 0: OFF



Command type	command	return	note
CAM_Shutter Pos Inq	8x 09 04 4A FF	y0 50 00 00 0p 0q	pq: Shutter Position
CAM_Iris Pos Inq	8x 09 04 4B FF	y0 50 00 00 0p 0q	pq: Iris Position
CAM_Gain Posi Inq	8x 09 04 4C FF	y0 50 00 00 0p 0q	pq: Gain Position
CAM_Gain Limit Inq	8x 09 04 2C FF	y0 50 0p FF	p:GainLimit 0x04~0x0F
CAM_AEBright Posi	8x 09 04 4D FF	y0 50 00 00 0p 0q	pq: Bright Position
CAM_ImageBrightPosiInq	8x 09 04 A4 FF	y0 50 00 00 0p 0q FF	pq: Image Bright Position 0x00~0x0F
CAM_WDR Mode Inq	8x 09 04 3D FF	y0 50 02 FF	On
		y0 50 03 FF	Off
CAM_GammaInq	8x 09 04 5B FF	y0 50 0p FF	p: Gamma posi
CAM_WDRLevInq	8x 09 04 2D FF	y0 50 0p FF	p : WDR LEVEL 1~6
CAM_SharpnessInq	8x 09 04 42 FF	y0 50 00 00 0p 0q	pq: Sharpness posi
SYS_Menu Mode Inq	8x 09 06 06 FF	y0 50 02 FF	On
		y0 50 03 FF	Off
CAM_LR_Reverse Inq	8x 09 04 61 FF	y0 50 02 FF	On
		y0 50 03 FF	Off
CAM_Picture Flip Inq	8x 09 04 66 FF	y0 50 02 FF	On
		y0 50 03 FF	Off
CAM_ID Inq	8x 09 04 22 FF	y0 50 0p 0q 0r 0s FF	pqrs: Camera ID
CAM_DHCP Inq	8x 09 04 AE FF	y0 50 pp FF	
CAM_IP Inq	8x 09 04 AB FF	y0 50 0p 0p 0q 0q	
		0r 0r 0s 0s FF	
CAM_MASK Inq	8x 09 04 AC FF	y0 50 0p 0p 0q 0q	
CAM_GATEWAY Inq	8x 09 04 AD FF	y0 50 0p 0p 0q 0q 0r 0r 0s 0s FF	
CAM_Version Inq	8x 09 00 02 FF	y0 50 ab cd mn pq rs tu vw FF	
Tally Inq	8x 09 7E 01 0A FF	y0 50 0p FF	p: tally state
TallyBrightnessInq	8x 09 7E 01 0A 01 FF	y0 50 0p FF	p: tally brightness
Freeze Inq	8x 09 04 75 FF	y0 50 0p FF	p: Freeze switch 3 = OFF 2 = ON
Preset Freeze Inq	8x 09 04 76 FF	y0 50 0p FF	p: Preset Freeze switch
PresetExist Inq	8x 09 04 3F 0p 0s FF	y0 50 0q FF	pp: preset NO. 0~255
Preset Speed Set Inq	8x 09 7E 01 0B FF	y0 50 pp FF	pp: Preset Speed 2~24 default:15
CAM_Inq_AT_OnOff_In	8x 09 04 C8 FF	y0 50 0p FF	P: 0 = off
CAM_Inq_AT_TargetChange_Inq	8x 09 04 CA FF	y0 50 0p FF	P:0x02 right move
CAM_Inq_TargetLocation_Inq	8x 09 04 CB FF	y0 50 0p FF	P: 0:mid 1:left 2:right
CAM_Inq_TargetRatio_Inq	8x 09 04 CC FF	y0 50 0p 0q FF	Pq:(6~20)Human is 1/pq in the pic
CAM_AT_ChangeTime	8x 09 04 CD FF	y0 50 0p 0q FF	Pq: t*10
CAM_AT_BlackBoardM	8x 09 04 CE FF	y0 50 0p FF	p: 1=Enable 0=Disable



Command type	command	return	note
CAM_AT_HilightTarget	8x 09 04 CF FF	y0 50 0p FF	p: 1=Enable 0=Disable
CAM_AT_ZoomLock_In	8x 09 04 D6 FF	y0 50 0p FF	p: 1=Enable 0=Disable
CAM_AT_LimitEnable_I	8x 09 04 D7 FF	y0 50 0p FF	p: 1=Enable 0=Disable
CAM_AudioInq	8x 09 04 D8 FF	y0 50 0p 0q 0r 0s 0t 0u 0m 0n 0h 0i 0j FF	0p: 0x01-ON 0x00-OFF 0q: 0x01-line in rstu: samplerate
Video System	8x 09 06 23 FF	y0 50 pp FF	pp: Video format
Video System	8x 09 04 24 72	y0 50 0p 0p FF	pp: Video format
SDIFeaturePositionInq	8x 09 06 32 FF	y0 50 0p 0q 0r 0s 0m 0n 0x 0y FF	pqrs:(x position)
SDIFeaturePositionCstl	8x 09 06 33 FF	y0 50 0p FF	p= position
IR_Receive	8x 09 06 08 FF	y0 50 02 FF y0 50 03 FF	On Off
Pan-tilt Max Speed Inq	8x 09 06 11 FF	y0 50 ww zz FF	ww: Pan Max Speed zz: Tilt Max Speed
Pan-tilt Pos Inq	8x 09 06 12 FF	y0 50 0w 0w 0w 0w	www: Pan Position zzzz: Tilt Position
Mainstream Resolution Inq	8x 09 04 C2 00 FF	y0 50 0p 0q 0r 0s 0m 0n 0x 0y FF	pqrs : Column(x size) mnxy: Line (y size)
Main stream Rate Inq	8x 09 04 C2 01 FF	y0 50 0p 0q 0r 0s 0m 0n 0x 0y FF	pqrsmnxy: bitrate (1024~61440kbps)
Main Encode Mode Inq	8x 09 04 C2 02 FF	y0 50 pp FF	Mode sel:0xpp
Main Frame Rate Inq	8x 09 04 C2 03 FF	y0 50 pp FF	Frame rate:0xpp
Main IDR Inq	8x 09 04 C2 04 FF	y0 50 pp FF	IDR Setting:0xpp
Main Stream Rate Mode Inq	8x 09 04 C2 05 FF	y0 50 pp FF	Contor mode:0xpp
Sub stream Resolution Inq	8x 09 04 C3 00 FF	y0 50 0p 0q 0r 0s 0m 0n 0x 0y FF	pqrs : Column(x size) mnxy: Line (y size)
Sub stream Rate Inq	8x 09 04 C3 01 FF	y0 50 0p 0q 0r 0s 0m 0n 0x 0y FF	pqrsmnxy: bitrate (1024~2048kbps)
Sub Encode Mode Inq	8x 09 04 C3 02 FF	y0 50 pp FF	Mode sel:0xpp
Sub Frame Rate Inq	8x 09 04 C3 03 FF	y0 50 pp FF	Frame rate:0xpp
Sub IDR Inq	8x 09 04 C3 04 FF	y0 50 pp FF	IDR Setting:0xpp
Sub Stream Rate Mode Inq	8x 09 04 C3 05 FF	y0 50 pp FF	Contor mode:0xpp
CAM_GL_Vertical	8x 09 04 3E FF	y0 50 0p 0q 0r 0s FF	pqrs: -200~200



Command type	command	return	note
CAM_GL_Phase	8x 09 04 3B FF	y0 50 0p 0q 0r 0s FF	pqrs: -206~49
CAM_GL_PhaseStep	8x 09 04 3C FF	y0 50 0p FF	p: 1~10
CAM_SystemMode_Inq	8x 09 06 34 FF	y0 50 0p FF	p: 0=FULL NDI priority 1=Digital priority
CAM_Phantom_power_Inq	8x 09 04 D9 FF	y0 50 0p FF	p: 2=Enable 3=Disable



Note: In the above table, **[x]** represents the camera address to be operated, and **[y]** = **[x + 8]** .

OSD Menu

1. Press the key  in normal operation mode to enter the following interface: Once in the menu, use the navigation up/down keys to select the desired main menu item. As shown in the image above, the highlighted blue section indicates the selected item. Parameters available under the selected item will be listed on the right side of the menu.

MENU			
SYSTEM	PROTOCOL	<	VISCA >
EXPOSURE	ADDRESS	<	1 >
IMAGE	BAUDRATE	<	9600 >
WHITE BALANCE	LANGUAGE	<	ENGLISH >
VIDEO	TALLY BRIGHTNESS	<	HIGH >
ZOOM & FOCUS	MODEL NO.		Z6 20X
IP SETTINGS	VERSION DATE		20250422
RECORD	CAMERA VERSION		662
RESET			

-1/1-

2. Once in the menu, use the navigation up/down keys to select the desired main menu item. As shown in the image above, the highlighted blue section indicates the selected item. Parameters available under the selected item will be listed on the right side of the menu.
3. To return to the previous menu level, press the [] key again. To exit the menu, press the [] key on the main screen once more.



Menu Setting Overview

<i>System</i>	Protocol	Options: Visca, Pelco-P, Pelco-D, Tlc	Default: Visca
<i>Settings</i>	Address	Visca:1~7 Pelco-P/D:1~255	Default: 1
	Bitrate	Options:2400、4800、9600、115200	Default: 9600
	Language	Optional: Zh-Ch, English, Zh-Tw, Russian	Default: English
	Tally	Optional: Off, Low, Middle, High	Default: Middle
	Brightness		
	Product Model	VISION+ 4KZ	
	Version Date	Release Date of Control Firmware Version (ARM)	
	Camera Version	(ISP) Version	

Exposure Exposure Mode AUTO、MANUAL、BRIGHT、SHUTTER、IRIS Default: AUTO

Shutter	Shutter speed: 1/8~1/10000, only valid under MANUAL and SHUTTER mode	Default: AUTO
Iris	Iris: F1.4 – F14 (Manual mode only)	Default: AUTO
Gain	Gain: 0~30dB (Manual mode only)	Default: AUTO
Exposure Bright	Exposure Brightness: 0~27 (Valid in BRIGHT mode,	Default: AUTO
Bright	Gain Limit: Max auto gain, 8~30dB	Default:30db
Wide Dynamic Mode	Global Brightness: 0~15	Default: 8
Wide Dynamic Level	WDR: ON / OFF	Default: OFF
Iris	WDR Level: 1~6 (Effective when WDR is ON,	Default: 1
Backlight Compensation:	Backlight Compensation: ON / OFF	Default: OFF
Anti-Flicker:	Anti-Flicker: 50Hz / 60Hz / OFF	Default: 50HZ
Day/Night Mode	Controls IRCut switching: DAY、Night	Default: Day

Image Parameters	2D Noise Reduction	2D noise reduction switch. When enabled, image noise decreases but sharpness may reduce.	OFF
	3D Noise Reduction	3D noise reduction level: OFF/AUTO/1~4. Higher levels reduce motion noise but may cause motion blur.	AUTO
	Sharpness	Image sharpness: 0~15. Higher values increase edge sharpening.	3
	Contrast	Image contrast level.	8
	Gamma Curve	Gamma curve selection: 0~15	8
	Horizontal Flip	Toggle for flipping the image left/right.	OFF
	Vertical Flip	Toggle for flipping the image up/down.	OFF
White Balance	White Balance Mode	Options: ATW, MANUAL, C.T., AUTO, INDOOR, OUTDOOR	ATW
	Red Gain	Red gain level: 0~255 (only valid in manual WB mode)	AUTO
	Blue Gain	Blue gain level: 0~255 (only valid in manual WB mode)	AUTO
	Color Temperature	Environmental color temperature: 2500~10000 (increments of 100)	AUTO
	Color Saturation	Image color saturation (vividness): 0~15	8
	Image Style	Options: USER, NORMAL, COLORFULL	USER
Video Parameters	HDMI Resolution	HDMI output resolution: 2160P, 1080P, 1080i, 720P	1080P
	HDMI Frame Rate	HDMI output frame rate: 60, 59.94, 50, 30, 29.97, 25, 24, 23.98	60
	Preview Type	HDMI output video type: FULL, FEATURE	FULL
	Video Source Frame Rate	Sensor output to ISP frame rate: 60, 25, 30, 50	60
Zoom/Focus	Zoom Value	Displays current lens zoom value.	-
	Focus Value	Displays current focus value.	-



	Zoom Speed	Zoom speed setting: 1~7	5
	Focus Speed	Focus speed setting: 1~7	3
	Focus Mode	Options: AUTO, MANUAL	AUTO
	Focus Area	Auto-focus area: ALL/TOP/BOTTOM/CENTER	ALL
	Focus Limit	Minimum focus distance: 1.5M, 2M, 3M, 6M, 10M	1.5M
	Focus Sensitivity	Options: HIGH, NORMAL, LOW	NORMAL
	Save AE & AW	Whether to save AE and AW settings when saving presets. Options: ON/OFF	OFF
	Preset Zoom Speed	Preset zoom speed: 1~7	5
Network Settings	DHCP	Enable DHCP: ON/OFF	ON
	IP Address	Example: 192.168.001.188	192.168.1.188
	Subnet Mask	Example: 255.255.255.000	255.255.255.0
	Gateway	Example: 192.168.001.001	192.168.1.1
Recording Settings	DNS	Example: 8.8.8.8	-
	Recording Switch	Control recording: ON/OFF	OFF
	Video Quality	Recording file quality: MAIN (primary stream), SUB (sub-stream)	MAIN
	File Duration	Recording file duration: 1~120 minutes	5
Factory Reset	SD Card Status	SD card usage: NO CARD, BADATA (corrupted data), BADCARD (faulty card)	Displays current SD card status
	Image Reset	Restores image parameters to factory defaults.	-
	Full Reset	Restores all parameters to factory defaults.	

IP Address Settings in the Menu

To facilitate customer debugging, the camera supports setting the IP address directly in the menu. The steps are as follows:

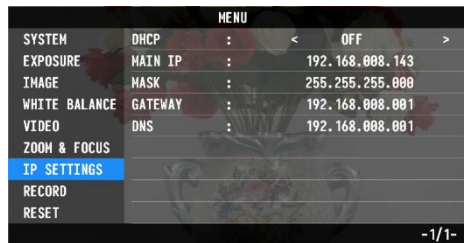

1. Press the **Menu** button to open the menu interface, then select "**Network Parameters**" to access the IP settings.
2. Use the remote control's **navigation keys** (**▲/▼/◀/▶**) to enter the IP settings interface. Adjust parameters such as **IP Address**, **Subnet Mask**, and **Gateway** accordingly.
3. Press the **numeric keys** to input values. After setting a parameter, press the **Menu** button again to confirm.
4. To exit the menu, press the **Menu** button once more.

Camera Button Functions

The camera is equipped with an **LCD screen and physical buttons** for easy parameter adjustment.

- The **LCD** displays the camera's parameter menu, and the buttons allow menu navigation (similar to the remote control).
- Use the **▲/▼/◀/▶** buttons to move the cursor and adjust settings.
- **Short-press** the **OK** button to confirm settings.
- **Long-press** the **OK** button to return to the previous menu.

The **LCD menu design is similar to the OSD menu**. For detailed operations, refer to the "**OSD Menu Configuration**" section above.

WEB Interface

No additional video player plugins are required—preview the live feed directly in a web browser.

Supported browsers: Chrome, Firefox, IE, Safari, Opera, 360, QQ, etc.

1. Login

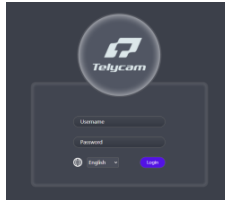

- Open a browser and enter the **IP address** (default: **192.168.1.188**).
- Select a **language** (Chinese, English, Korean, Portuguese, or Spanish).
- Enter the **username** and **password** (default: **admin/admin**).

2. PTZ Control

After logging in:



- The **left side** displays the live preview.
- The **right side** allows, including **zoom**, **focus**, **preset positions**, and **speed adjustment** via sliders.



3. Camera Settings

Click "Camera Settings" to access:

- **Exposure:** Mode, anti-flicker, shutter, gain, iris, brightness, etc.

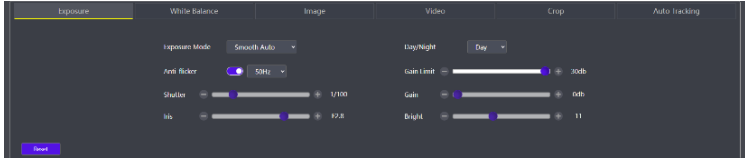

- **White Balance:** Mode, red gain, blue gain, color temperature, etc.

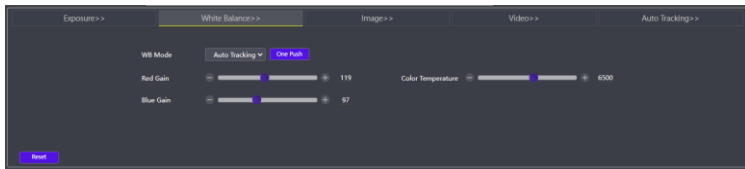

- **Image:** Saturation, contrast, sharpness, brightness, backlight compensation, WDR, 2D/3D noise reduction, gamma, etc.



- **Video:** Output mode, source frame rate, digital output, mirror/flip, e-zoom, etc.

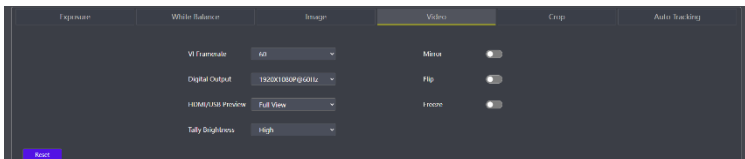

- **Crop:** Crop Size, Position, Crop preset, Preview

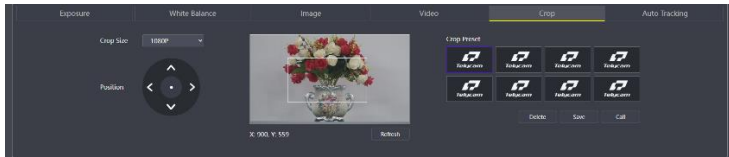

- **Auto Tracking:** Tracking switch, target position, target ratio, timeout settings, PTZ limits, whiteboard settings, etc.

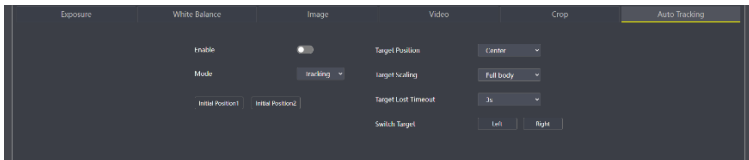

4. IP Settings

Click "**IP Settings**" to configure:

- **Video Encoding:** Primary/secondary stream, encoding mode, profile, resolution, bitrate, frame rate, I-frame interval, RTSP address, etc.
- **Audio Settings:** Audio switch, encoding mode, sample rate, bitrate, volume, etc.
- **SRT Settings:** Mode, enable/disable, port, latency, encryption, etc.
- **RTMP Settings:** Enable/disable, RTMP address.
- **NDI|HX3:** Enable NDI/HX3, device name, channel name, multicast, etc.
- **FreeD:** Enable/disable, camera ID, mode, IP, port, interval, etc.
- **Ethernet:** DHCP, IP address, subnet mask, gateway, HTTP/RTSP ports, VISCA port, RTSP encryption, etc.



5. Management

Click "**Management**" to access:

- **Firmware Upgrade:** View device info, hardware/software versions, and upload firmware.



- **System Management:** Export/import configurations, reboot, reset, or schedule automatic reboots.
- **Account Settings:** Modify login credentials.
- **Time Settings:** NTP (enable/disable, timezone, update interval, server address/port).
- **Recording Settings:** Enable recording, live capture, file size, loop recording, frequency. Download recorded files or start manual recording.
- **SD Card Settings:** Format SD card.

6. Logout

Click "**Logout**" to return to the login screen.

View RTSP video using VLC player

Default RTSP main streaming address:

```
rtsp://192.168.1.188/stream/main
```

Default RTSP sub streaming address:

```
rtsp://192.168.1.188/stream/sub
```

Default RTMP main streaming address: `rtmp://192.168.1.188:1935/app/rtmpstream0`

Default RTMP sub streaming address: `rtmp://192.168.1.188:1935/app/rtmpstream1`

1. Run VLC Media Player.
2. Media->network stream, to enter into "open media" interface.
3. Input RTSP address in URL as following:

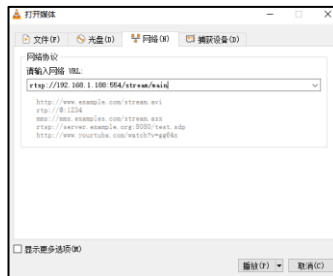

4. Click play to view the real time image.

Note: If there is much image lag, select "more option" to enter into following setting, change buffer time smaller (VLC default buffer time is 1000ms).





As shown in the figure above, after opening the video in Studio Monitor, a settings icon will appear in the lower right corner of the video. Clicking this icon will bring up the camera WEB interface. For specific operations, please refer to the 'WEB Settings' section.

3. Using NDI Tools Virtual Input as a Virtual CAMERA

Locate and open NDI Tools/Virtual Input in the Windows toolbar, and the NDI Virtual Input icon will be displayed in the Windows taskbar, as shown in the figure below:



Right-click on the NDI Virtual Input icon and select the desired virtual device name.

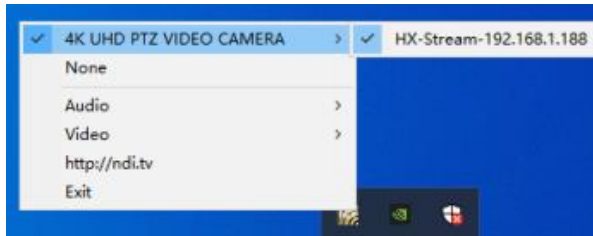

Taking Zoom as an example, select 'NewTek NDI Video' as the camera in the video options, as shown in the figure below. This method is also applicable to video conferencing software such as GotoMeeting, Skype, and Hangouts.





VISCA over IP

VISCA over IP means VISCA protocol transmit via IP, to reduce RS232/RS485 cable layout (the controller must support IP communication function)

Communication port spec:

- Control port: RJ45 Gigabit LAN
- IP protocol: IPv4
- Transmit protocol: UDP
- IP address: set via web end or OSD menu
- Port address: 52381
- Confirm send/transmission control: depend on applied program
- Applied range: in the same segment, not suitable for bridge network
- Turn on camera: In the menu, set VISCA option to OVER IP or OVER ALL

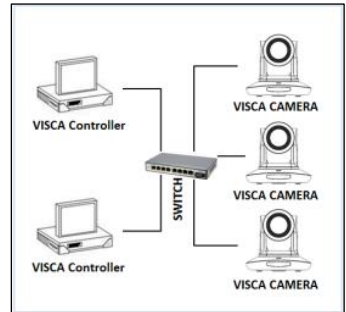

IP Networking method

How to use VISCA over IP

VISCA Command means commands from controller to peripheral equipment, when peripheral equipment receives commands, then return ACK. When commands executed, will return complete message.

For different commands, camera will return different message.

VISCA Inquiry: It means inquiry from controller to peripheral equipment when peripheral equipment receives this kind of commands, it will return required message.

VISCA Reply: It means ACK, complete message, reply or error reply, it is sent from peripheral equipment to controller.



Command format: the following is message head and valid message format.

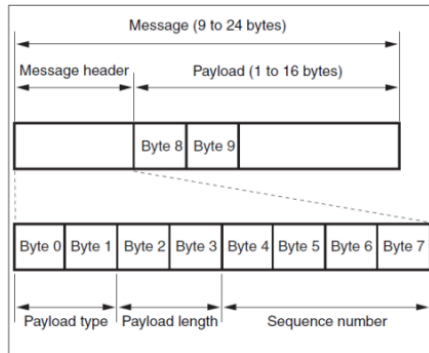

Note: LAN output way is big-endian, USB is in the front.

Payload type:

Data definition as following:

<i>Name</i>	Value (Byte 0)	Value (Byte1)	Value
<i>VISCA command</i>	0x01	0x00	Stores the VISCA command.
<i>VISCA inquiry</i>	0x01	0x10	Stores the VISCA inquiry.
<i>VISCA reply</i>	0x01	0x11	Stores the reply for the VISCA command and VISCA inquiry, or VISCA device setting command.
<i>VISCA device setting command</i>	0x01	0x20	Stores the VISCA device setting command.
<i>Control command</i>	0x02	0x00	Stores the control command.
<i>Control reply</i>	0x02	0x01	Stores the reply for the control command.



Payload length

Valid data length in Payload (1~16), is command length.

For example, when valid data length is 16 byte

Byte 2 : 0x00

Byte 3 : 0x10

Controller will save sequence number of each command, when one command sent, the sequence number of the command will add 1, when the sequence number becomes the max value, it will change to 0 for next time. The peripheral equipment will save sequence number of each command, and return the sequence number to the controller.

Payload

According to Payload type, the following data will be saved.

- VISCA command

Save VISCA command packet

- VISCA inquiry

Save VISCA message packet

- VISCA reply

Save VISCA return packet

- VISCA device setting command

Save VISCA equipment setting command packet.

- Control command

The following data is saved in control command payload

<i>Name</i>	<i>Value</i>	<i>Description</i>
<i>RESET</i>	0x01	Resets the sequence number to 0. The value that was set as the sequence number is ignored.
<i>ERROR</i>	0x0Fyy	yy=01:Abnormality in the sequence number.
		yy=02:Abnormality in the message(message type).

- Controlled reply

The following data is saved in return command payload of control command.

<i>Message</i>	<i>Value</i>	<i>Description</i>
<i>ACK</i>	0x01	Reply for RESET.

Delivery confirmation

VISCA over IP uses UDP as transmission communication protocol, UDP communication message transmission is not stable, it is necessary to confirm delivery and resent in application.

Generally, when controller sends a command to peripheral equipment, controller will wait for the return message then send the next command, we can detect and confirm if the peripheral equipment receive the commands from return message's lag time. If controller shows it is overtime, it is regarded as error transmission.



If controller shows it is overtime, resend the commands to check peripheral's status, resend command sequence number is same as last command, the following chart list the received message and status after resending the commands.

Lost message	Received message for retransmission	Status after retransmission	Correspondence after retransmission
Command	ACK message	Command is performed by retransmission.	Continue processing.
ACK message	ERROR (Abnormality in the sequence number.)	Command has been performed. If only the ACK message is lost, the completion message returns.	If the result by the completion message is needed, retransmit by updating the sequence number.
Completion message for the command	ERROR (Abnormality in the sequence number.)	Command has been performed.	If the result by the completion message is needed, retransmit by updating the sequence number.
Inquiry	Reply message	Inquiry is performed by retransmission.	Continue processing.
Reply message for the inquiry	ERROR (Abnormality in the sequence number.)	Inquiry has been performed.	If the result by the reply message is needed, retransmit by updating the sequence number.
Error message	Error message	Command is not performed. If the error cause eliminates, normal reply is returns (ACK, reply message).	Eliminate the error cause. If normal reply returns, continue processing.
Inquiry of the VISCA device setting command	Reply message of the VISCA device setting command	Inquiry has been performed by retransmission.	Continue processing.
Reply message of the VISCA device setting command	ERROR (Abnormality in the sequence number.)	Inquiry has been performed.	If the result by the reply message is needed, retransmit by updating the sequence number.

Sequence chart as following

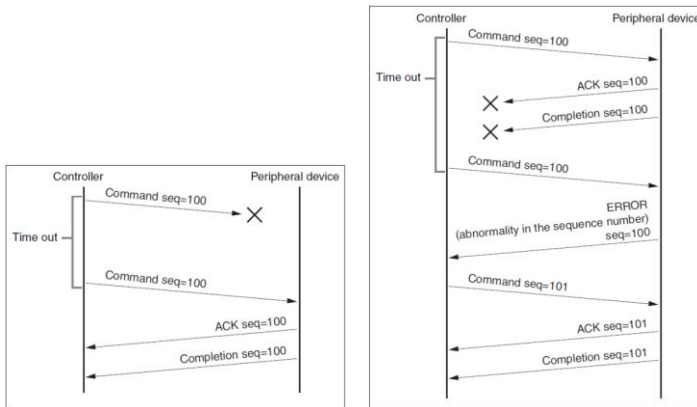

Sequence chart when command lost

Sequence chart when returned message lost

Note: Do not set IP address, sub net mask, gateway parameter in VISCA over IP command, otherwise, it will cause network breaks off. Due to change these parameter, network will be in off status.