



RDL®

High Performance Audio Products. Made in America.

TWISTED PAIR FORMAT-A Models D-TPS3A, DB-TPS3A, DS-TPS3A Format-A Three-Pair Senders



- **Balanced Microphone XLR Input with Phantom**
- **Switch-Selectable Mic Gain on Rear Panel**
- **Two Unbalanced -10 dBV Phono Jack Line Inputs**
- **MIC Feeds Pair A; L Feeds Pair B; R Feeds Pair C**
- **Remote Powering through Twisted Pair Cable**
- **Fused Local Power Feeds all Connected Modules**
- **Local Power Input on Terminal Block**
- **Blue LED Indicates Module is Powered**
- **Utilizes All Three Format-A Pairs**
- **Studio-Quality Precision Active Balanced Circuitry**

The D SERIES-TPS3A modules are three-pair audio sending modules compatible with RDL Format-A twisted pair products. These modules are designed to be mounted in wall boxes, cabinets or other enclosures that allow users to connect audio sources. The -TPS3A models mount in RDL WB-1U and WB-2U wall boxes, or in standard U.S. electrical boxes. The D-TPS3A features a white front-panel laminate with gray lettering that matches RDL Decora®-style remote controls. The DB-TPS3A features a black front-panel laminate. The DS-TPS3A is constructed of stainless steel to coordinate with RDL Decora-style stainless steel remote controls in commercial/industrial installations.

APPLICATION: The D SERIES-TPS3A modules features an XLR microphone input and two RCA phono jack inputs, one for the left channel source and one for the right channel source. The unbalanced inputs are designed to receive standard -10 dBV consumer level signals. The microphone input provides 24 Vdc IEC phantom voltage and accepts both dynamic and condenser microphone signals. The input signals are amplified using studio-quality preamplifiers optimized for normal operating levels. A rear-panel GAIN switch is provided to set the amplification of the microphone preamplifier. This switch is normally set by the installer for NORM (normal) gain. If consistently low mic levels are expected, this switch may be set to the HIGH gain position. The pre-amplified microphone source is routed to pair A. The buffered left and right line-level inputs are routed to output cable pairs B and C.

These modules drive all three FORMAT-A cable pairs, so they are not equipped to receive inputs from other sender modules. The D SERIES-TPS3A may not be connected together with any other sending modules.

The D SERIES-TPS3A may be powered directly from a 24 Vdc power supply using the rear-panel detachable terminal block. Local power connected to the module is also fed to all connected remote modules. The -TPS3A may be remotely powered through the twisted pair cable from any other module, signal distributor or RDL power inserter connected to the same twisted pair cable. Module power is indicated by a front-panel LED.

RDL FORMAT-A features superior audio performance that rivals or exceeds shielded wiring. Design simplicity, ease of installation, unsurpassed flexibility, automatic fused power, exceptional hum rejection, low noise, and low distortion provide designers and installers the optimum choice in economical twisted pair products.



RDL®

High Performance Audio Products. Made in America.

FORMAT-A TWISTED PAIR Models D-TPS3A, DB-TPS3A, DS-TPS3A Format-A Three-Pair Senders

Installation/Operation

CE Declaration of Conformity available from rdlnet.com.
Sole EMC specifications provided on product package.
Specifications are subject to change without notice.

STEP 1: Set the MIC gain switch to NORM (normal gain) unless consistently low mic level signals are expected. Set the MIC gain switch to HIGH if low levels are always expected. Note: If both normal and low level mic signals are expected, the gain should be set to NORM to avoid clipping when high levels are connected.

STEP 2: Connect 24 Vdc to the power input terminals if this module is not being powered through the twisted pair cable from another module, or if this module is located an excessive distance from the next powered module on the cable. Note: The front-panel power LED will be illuminated if this module is powered. If this module is powering other modules through the cable and if there is a wiring short, the short must be cleared then power must be turned off to this module for 10 seconds to reset the internal protection circuit.

STEP 3: Connect the twisted pair cable(s) and fasten the module in its mounting box.

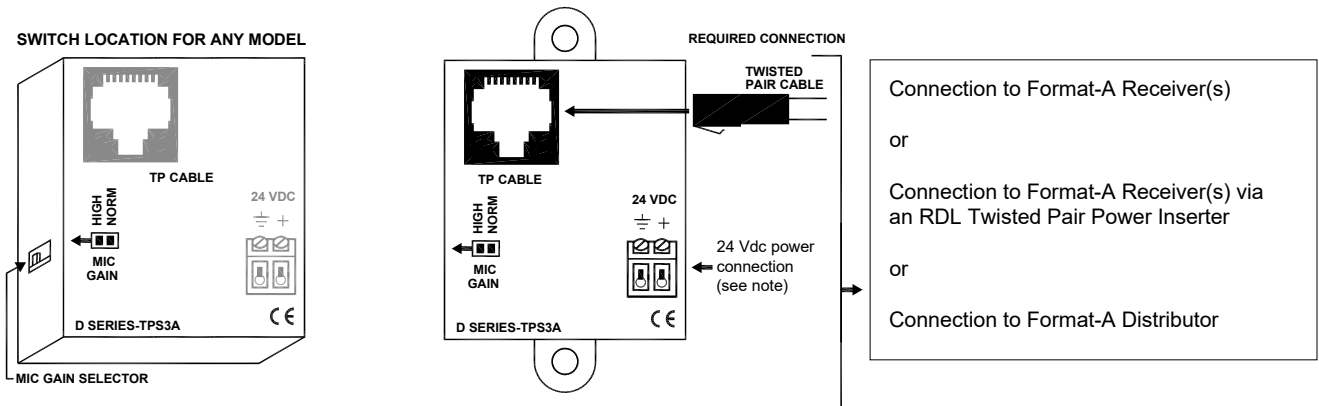

NOTE: Connect a 24 Vdc power supply to the module if power is not being supplied through a twisted pair cable from a connected module.

RJ45 Standard wiring

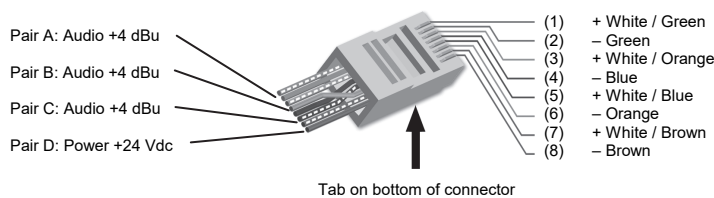

RJ45 conductor colors shown are for 568A standard. The 568B standard may be used if the connectors at both ends of the cable are wired identically.

TYPICAL PERFORMANCE

Inputs (3): Mic: 1.2 kΩ Bal. with IEC 24 Vdc Phantom; Line (left and right): 10 kΩ Unbal.
 Input Connection: Mic: XLR; Line: RCA Phono
 Input Level: Mic: -45 to -65 dBu Balanced; Maximum: -40 dBu (HIGH Gain), -28 dBu (NORM Gain);
 Line: -10 dBV Unbalanced; +10 dBV Max
 Format-A Signal Pairs: A (Mic); B (Unbalanced Line Left); C (Unbalanced Line Right)
 Gain: Mic: 50 dB (NORM) or 63 dB (HIGH), Switch-selectable on rear panel; Line: 12 dB
 Output: RDL TP Format-A
 Output Connection: RJ45
 Frequency Response: Mic: 100 Hz to 30 kHz (+/- 1 dB); integral low-cut filter -10 dB @ 30 Hz;
 Line: 20 Hz to 50 kHz (+/- 0.5 dB)
 THD+N: Mic: < 0.1% (80 Hz to 20 kHz); Line: < 0.05% (20 Hz to 50 kHz); < 0.005% (1 kHz)

Noise below +4 dBu:
 Crosstalk:

Headroom above +4 dBu:
 CMRR (50 to 150 Hz):
 Indicator:
 Power Connections (2):
 Power Requirement:
 Maximum Load Current:
 Dimensions:
 Mounting Box Minimum Depth:

Mic: < -80 dB (NORM Gain), < -70 dB (HIGH Gain); Line: < -95 dB
 Line to Line: < 90 dB (1 kHz); < 75 dB (20 Hz to 20 kHz); Line to Mic
 (HIGH Gain): < 65 dB (1 kHz), < 60 dB (20 Hz to 20 kHz);
 Line to Mic (NORM Gain): < 75 dB (1 kHz), < 70 dB (20 Hz to 20 kHz)
 > 18 dB
 Mic: > 60 dB (HIGH Gain), > 65 dB (NORM Gain)
 Power In
 Detachable terminal block; RJ45
 24 Vdc @ 65 mA plus connected loads
 135 mA
 .6" (4.06 cm) W; 4.11" (10.45 cm) H; 1.89" (4.8 cm) D
 2.4"

Radio Design Labs Technical Support Centers

U.S.A. (800) 933-1780, (928) 778-3554 - Europe [NH Amsterdam-Duivendrecht] ++31 20-6238 983