



# RDL®

High Performance Audio Products. Made in America.

## TWISTED PAIR FORMAT-A Models D-TPR2A, DB-TPR2A, DS-TPR2A Format-A Two-Pair Receivers



- Two Unbalanced -10 dBV Phono Jack Audio Outputs
- L (Left) Output From Pair B; R (Right) From Pair C
- Signal and Power Pair Pass-Through on RJ45s
- Remote Powering through Twisted Pair Cable
- Fused Local Power Feeds all Connected Modules
- Local Power Input on Terminal Block
- Blue LED Indicates Module is Powered
- Daisy-Chain with Additional Format-A Receivers
- Studio-Quality Precision Active Balanced Circuitry

The D SERIES-TPR2A modules are two-pair audio receiving modules compatible with RDL Format-A twisted pair products. These modules are designed to be mounted in wall boxes, cabinets or other enclosures that allow users to connect external equipment. The -TPR2A models mount in RDL WB-1U and WB-2U wall boxes, or in standard U.S. electrical boxes. The D-TPR2A features a white front-panel laminate with gray lettering that matches RDL Decora®-style remote controls. The DB-TPR2A features a black front-panel laminate. The DS-TPR2A is constructed of stainless steel to coordinate with RDL Decora-style stainless steel remote controls in commercial/industrial installations.

**APPLICATION:** The D SERIES-TPR2A modules feature two RCA phono jack outputs, one for the left channel output and one for the right channel. The audio signals received from pairs B and C of the twisted pair cable are buffered to drive the output jacks at the standard -10 dBV consumer level.

This module receives signal from only two cable pairs, so the D SERIES-TPR2A modules have a second RJ45 jack to connect cables to additional receiver modules. A separate single-pair receiver may be chained to the second RJ45 jack. In addition to completing the reception of signals from all three FORMAT-A pairs, additional receivers may be connected to the same twisted pair feed. The bridging input circuits used in all FORMAT-A twisted pair receivers allow connection of up to 10 receiver outputs for each cable pair. The possibility of multiple receiver locations adds enormous flexibility in the design of audio routing systems using RDL FORMAT-A products. The power pair and all three audio pairs are fed through both rear-panel RJ45 jacks.

The D SERIES-TPR2A may be powered directly from a 24 Vdc power supply using the rear-panel detachable terminal block. Local power connected to the module is also fed to all connected remote modules. The -TPR2A may be remotely powered through the twisted pair cable from any other module, signal distributor or RDL power inserter connected to the same twisted pair cable. Module power is indicated by a front-panel LED.

RDL FORMAT-A features superior audio performance that rivals or exceeds shielded wiring. Design simplicity, ease of installation, unsurpassed flexibility, automatic fused power, exceptional hum rejection, low noise, and low distortion provide designers and installers the optimum choice in economical twisted pair products.



# RDL<sup>®</sup>

High Performance Audio Products. Made in America.

## TWISTED PAIR FORMAT-A Models D-TPR2A, DB-TPR2A, DS-TPR2A Format-A Two-Pair Receivers

## Installation/Operation

**CE** Declaration of Conformity available from rdlnet.com. Sole EMC specifications provided on product package. Specifications are subject to change without notice.

**STEP 1:** Connect 24 Vdc to the power input terminals if this module is not being powered through the twisted pair cable from another module, or if this module is located an excessive distance from the next powered module on the cable. Note: The front-panel power LED will be illuminated if this module is powered. If this module is powering other modules through the cable and if there is a wiring short, the short must be cleared then power must be turned off to this module for 10 seconds to reset the internal protection circuit.

**STEP 2:** Connect the twisted pair cable coming from Format-A senders or distributors.

**STEP 3:** Connect the twisted pair cable feeding additional Format-A receiver(s), if any, and fasten the module in its mounting box.

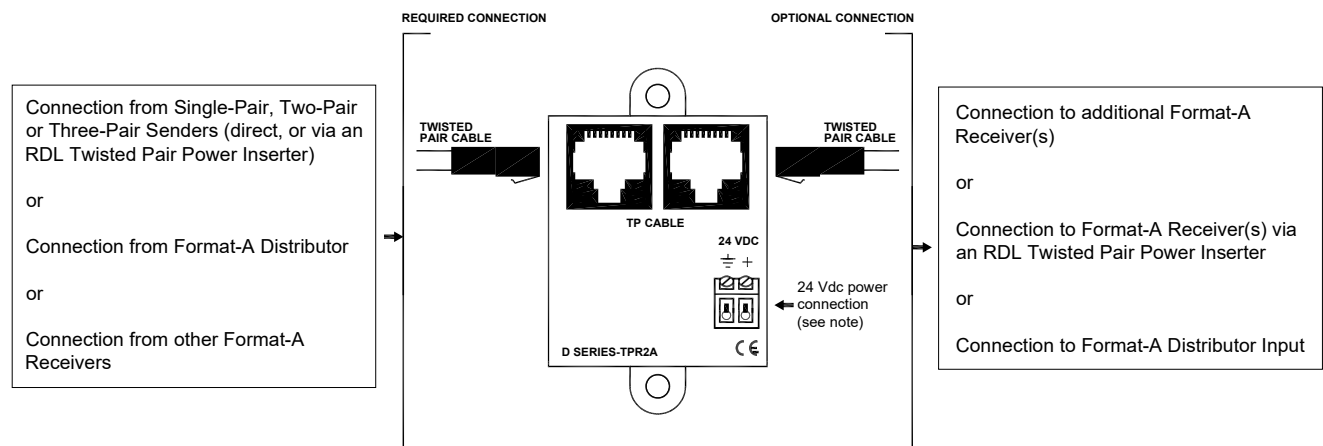

### RJ45 Standard wiring

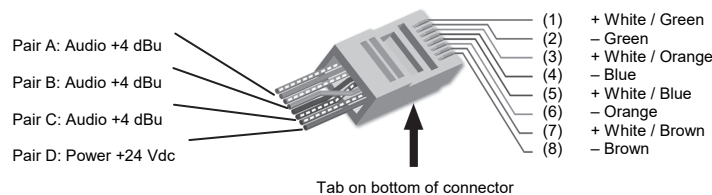

RJ45 conductor colors shown are for 568A standard. The 568B standard may be used if the connectors at both ends of the cable are wired identically.

### TYPICAL PERFORMANCE

Input: RDL FORMAT-A  
Input Connection: RJ45  
Format-A Signal Pairs Used (2): B (Left); C (Right)  
Format-A Output: RJ45  
Output: 100 Ω unbalanced  
Output Connection: RCA Phono  
Frequency Response: 10 Hz to 50 kHz (+/- 0.1 dB)  
THD+N: < 0.005%  
Noise below +4 dBu: < -90 dB

Crosstalk: < 90 dB (1 kHz); < 75 dB (20 Hz to 20 kHz)  
Headroom above +4 dBu: > 18 dB  
CMRR: > 80 dB (50 Hz to 150 Hz)  
Indicator: Power In  
Power Connections (2): Detachable terminal block; RJ45  
Power Requirement: 24 Vdc @ 45 mA plus connected loads  
Maximum Load Current: 155mA  
Dimensions: 1.6" (4.06 cm) W; 4.11" (10.45 cm) H; 1.89" (4.8 cm) D  
Mounting Box Minimum Depth: 2.4"

Radio Design Labs Technical Support Centers

U.S.A. (800) 933-1780, (928) 778-3554 - Europe [NH Amsterdam-Duivendrecht] ++31) 20-6238 983